

A decorative graphic on the left side of the slide, consisting of several overlapping blue rectangular shapes of varying heights and widths, creating a stepped effect.

TCP/IP Networking

Overview

- ❑ Introduction
- ❑ Layers of TCP/IP
 - Link Layer
 - Network Layer
 - Transport Layer
 - Application Layer
- ❑ Network Interface and Hardware
- ❑ Networking
- ❑ ARP
- ❑ Setting up Network

Introduction

- APRANET

Advanced Research Projects Agency Network

- NCP (Network Control Protocol)
 - Allow an exchange of information between separated computers

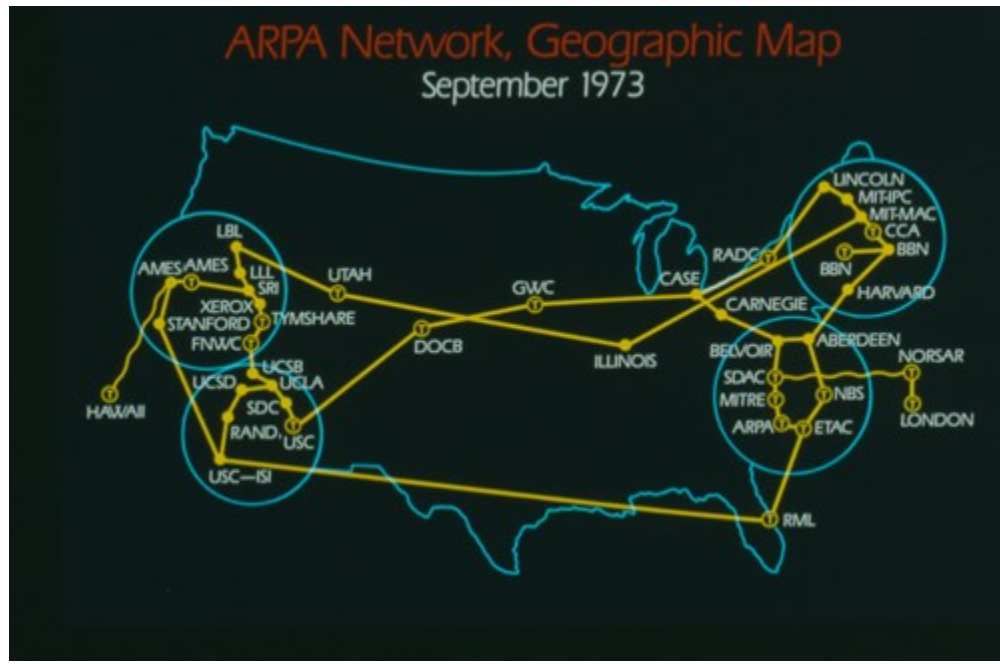
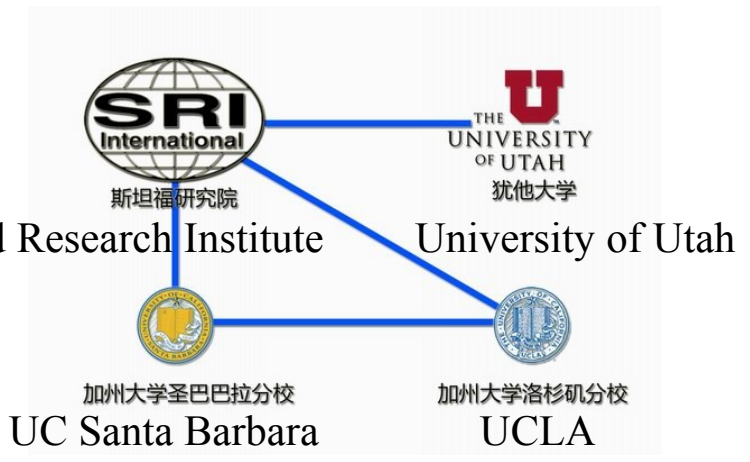

Introduction

– Why TCP/IP ?

- ❑ Transmission Control Protocol / Internet Protocol
- ❑ The gap between applications and Network
 - Network
 - 802.3 Ethernet
 - 802.4 Token bus
 - 802.5 Token Ring
 - 802.11 Wireless
 - 802.16 WiMAX
 - Application
 - Reliable
 - Performance

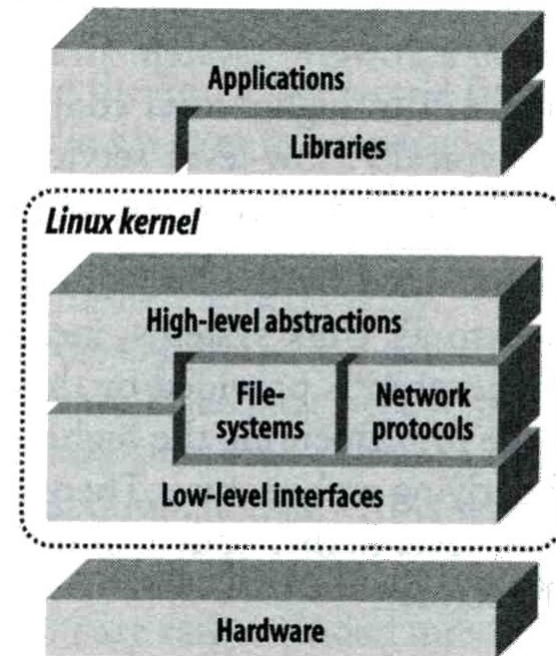

Introduction

– Layers of TCP/IP (1)

□ TCP/IP is a suite of networking protocols

- 4 layers Layering architecture
 - Link layer (data-link layer)
 - Include device drivers to handle hardware details
 - Network layer (IP)
 - Handle the movement of packets around the network
 - Transport layer (Port)
 - Handle flow of data between hosts
 - Application

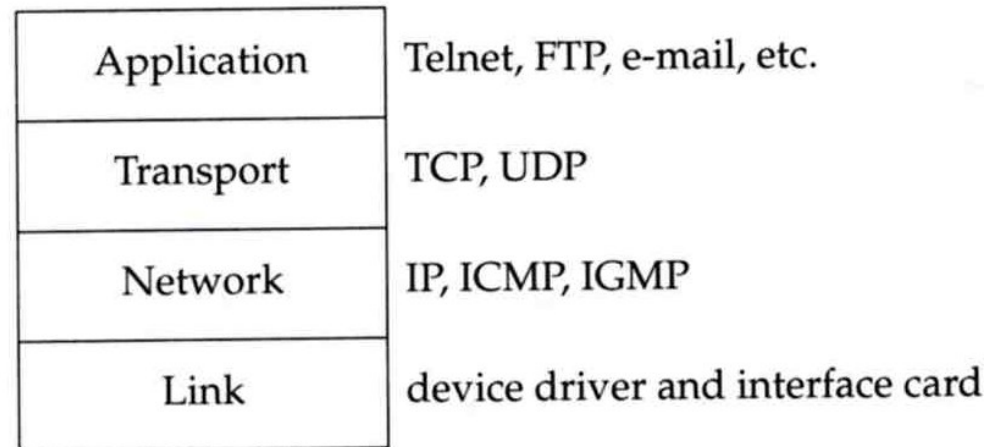

Introduction

– Layers of TCP/IP (2)

❑ ISO/OSI Model

(International Organization for Standardization / Open System Interconnection Reference Model)

❑ TCP/IP Model

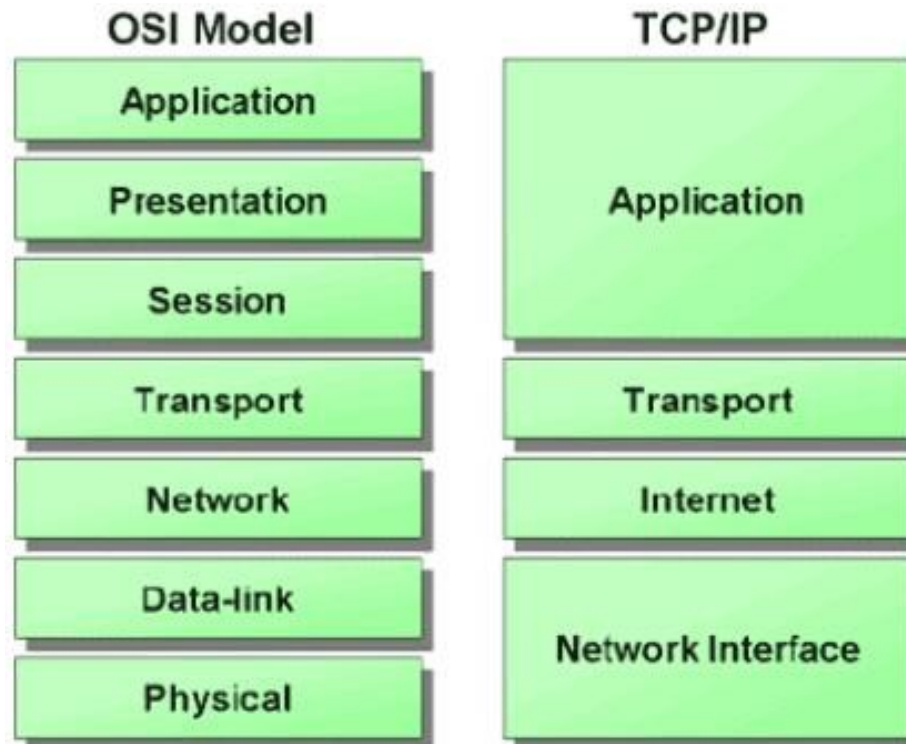

TCP/IP and the OSI model

Introduction

– Layers of TCP/IP (3)

❑ Encapsulation (Multiplexing)

- Gathering data from multiple sockets, enveloping data with header

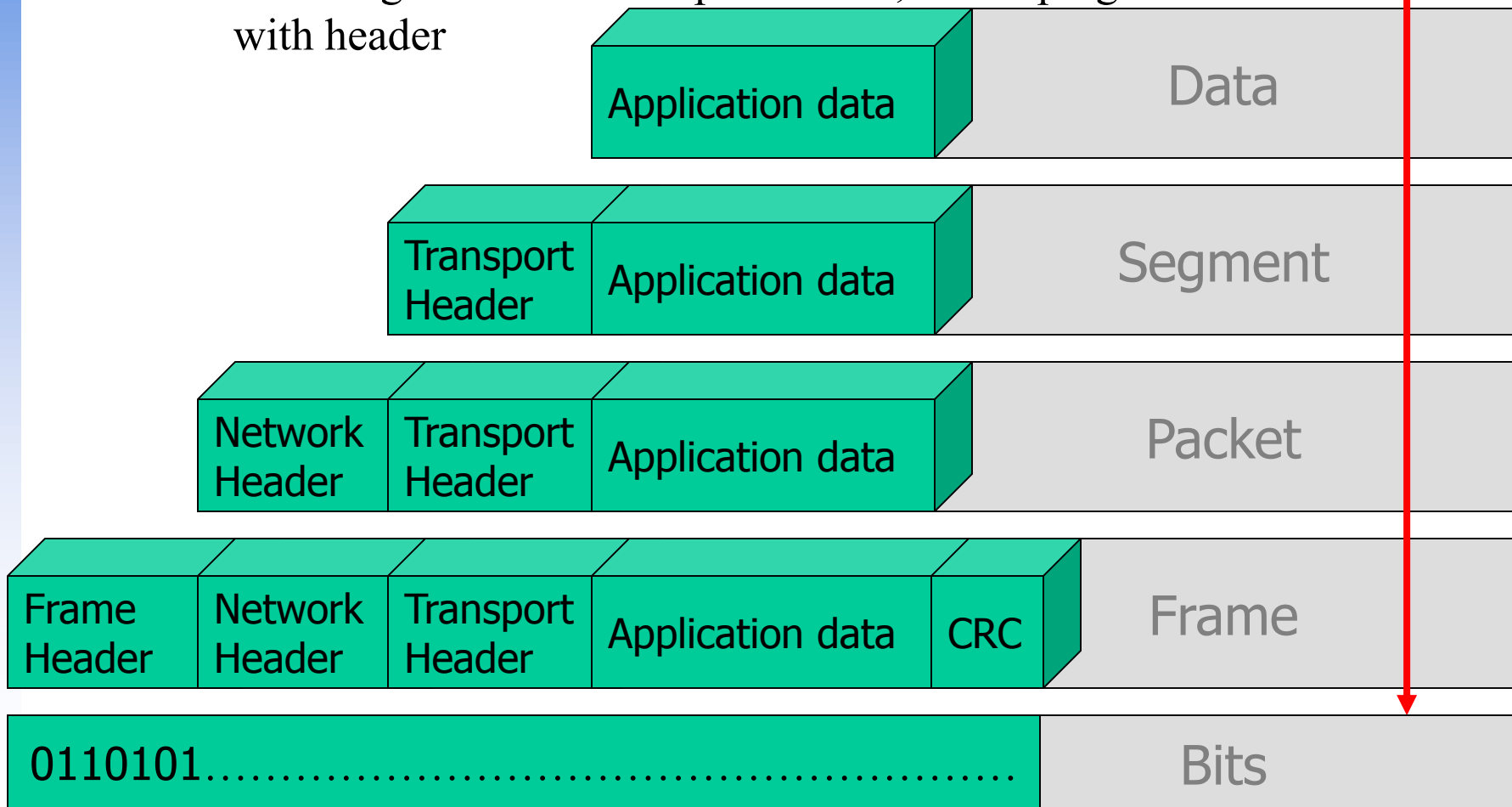

Introduction

– Layers of TCP/IP (4)

❑ Decapsulation (Demultiplexing)

- Delivering received segments to correct socket

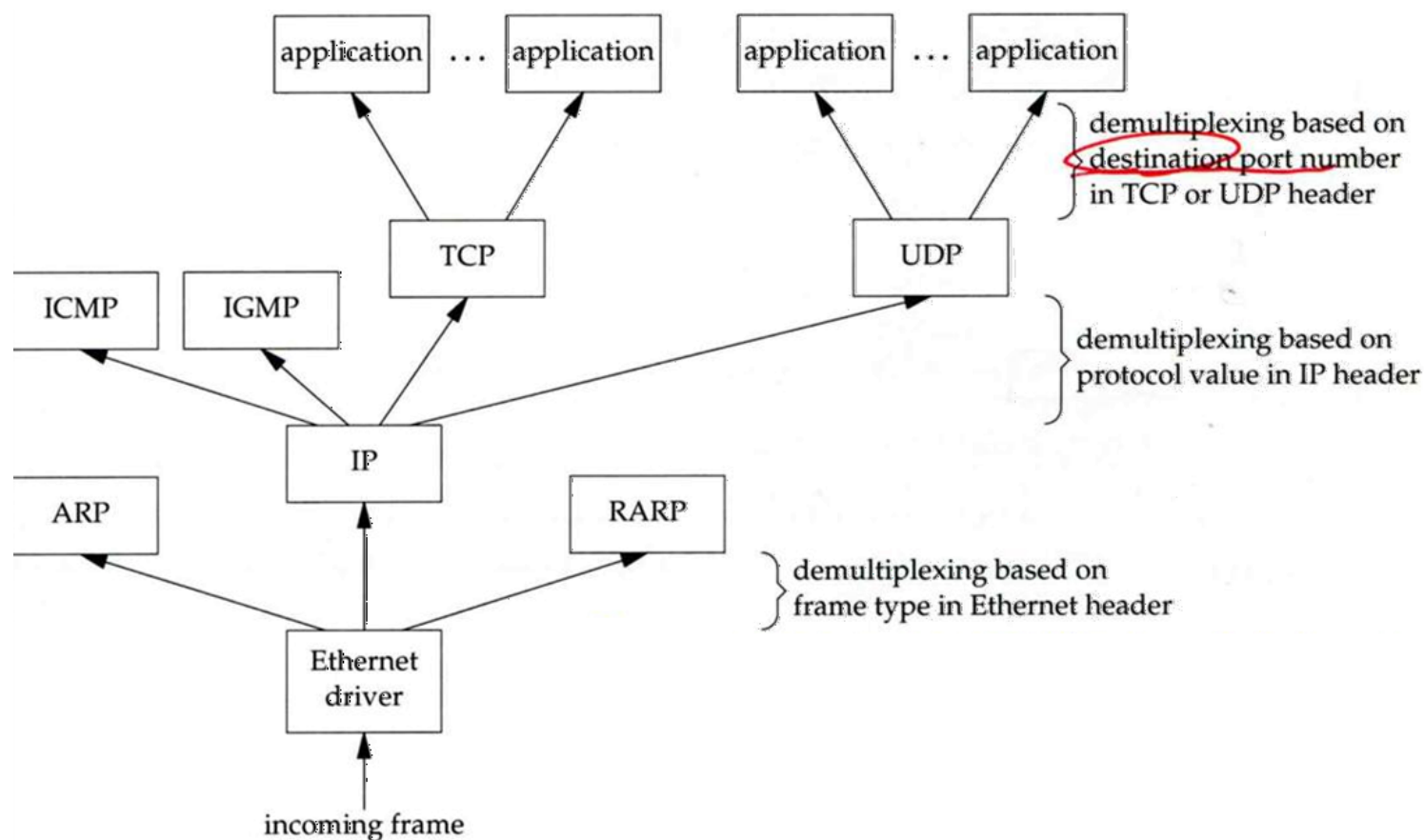
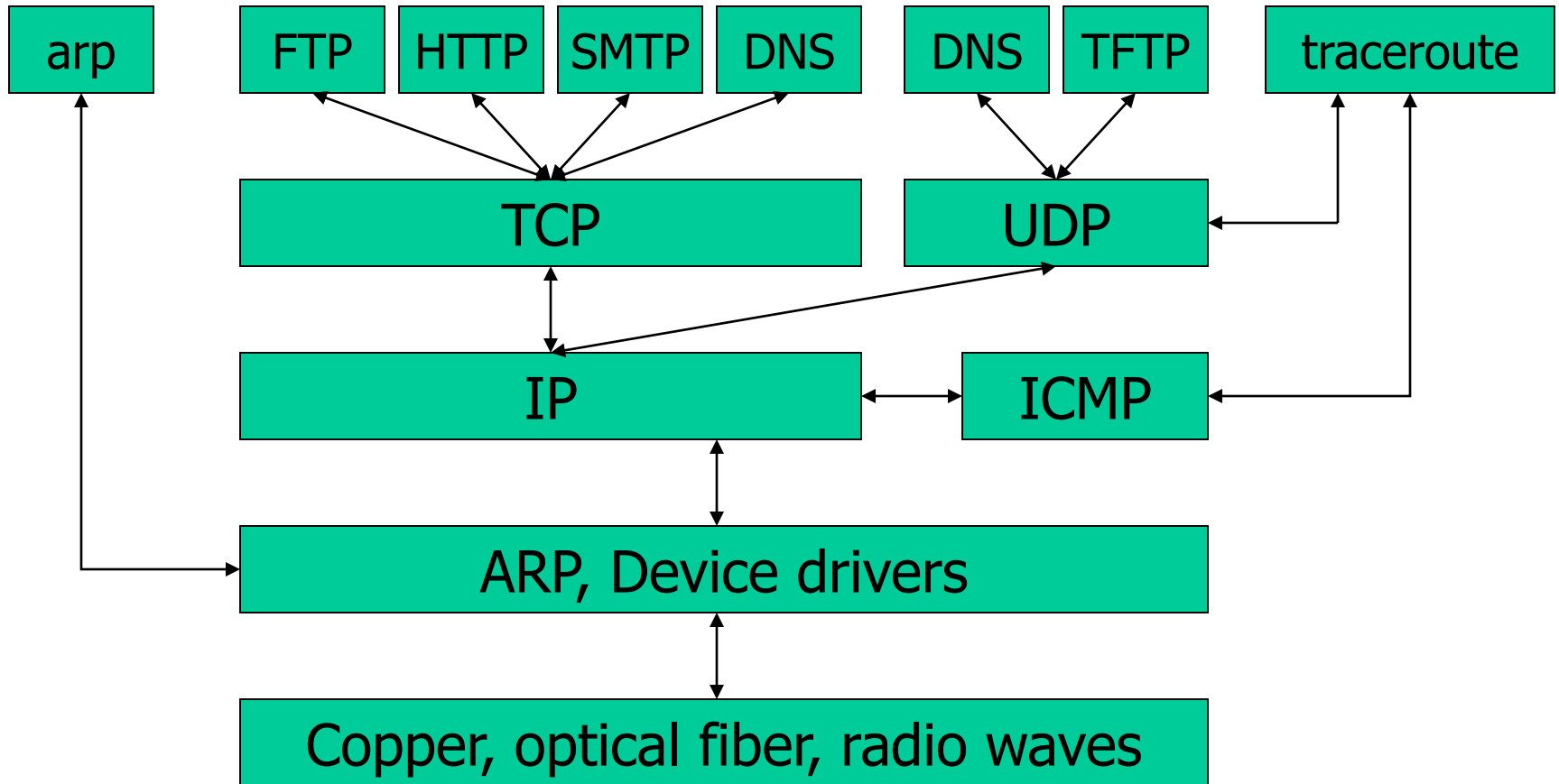

Figure 1.8 The demultiplexing of a received Ethernet frame.

Introduction

-TCP/IP Family



Introduction

– Addressing

□ Addressing

- Nearby (same network)

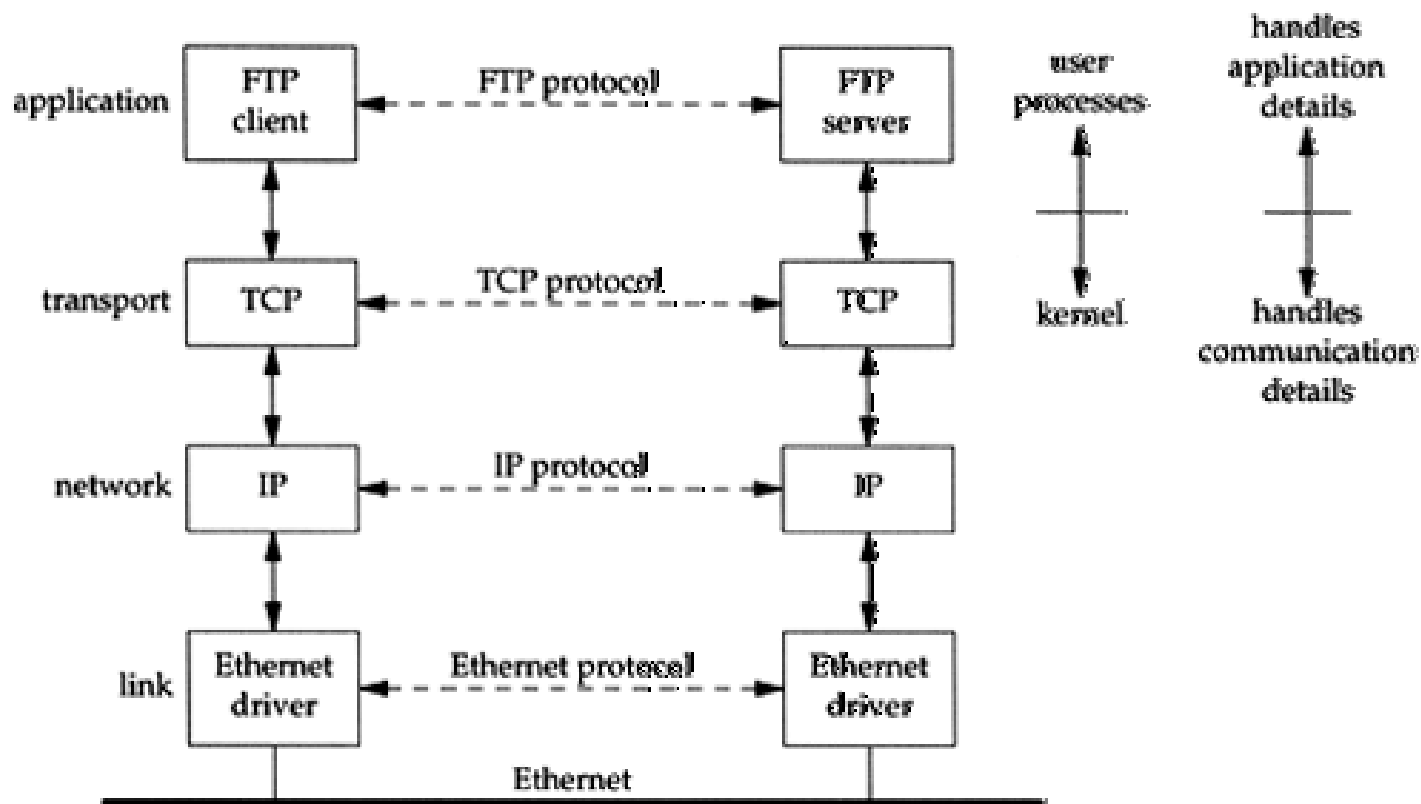

Introduction

– Addressing

□ Addressing

- Faraway (across network)

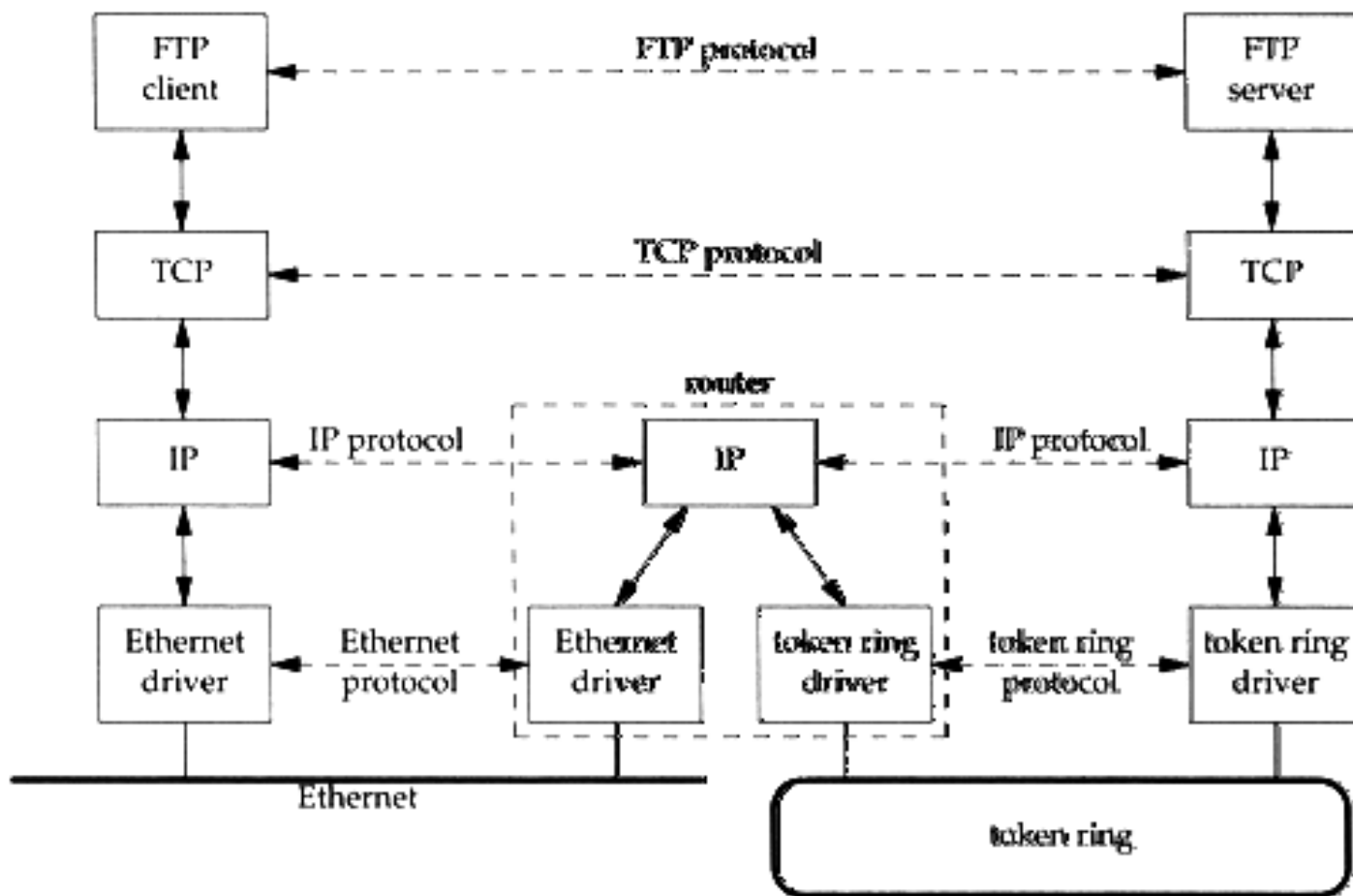

Introduction

– Addressing

- ❑ IP
 - 32-bits, Unique Internet Address of a host
- ❑ Port
 - 16-bits, Uniquely identify application
- ❑ MAC Address
 - Media Access Control Address
 - 48-bits, Network Interface Card (NIC) Hardware address

```
sabsd [/home/chwong] -chwong- ifconfig
sk0: flags=8843<UP,BROADCAST,RUNNING,SIMPLEX,MULTICAST> mtu 1500
options=b<RXCSUM,TXCSUM,VLAN_MTU>
inet 140.113.17.215 netmask 0xfffff00 broadcast 140.113.17.255
inet 140.113.17.221 netmask 0xffffffff broadcast 140.113.17.221
ether 00:11:d8:06:1e:81
media: Ethernet autoselect (100baseTX <full-duplex,flag0,flag1>)
status: active
lo0: flags=8049<UP,LOOPBACK,RUNNING,MULTICAST> mtu 16384
inet 127.0.0.1 netmask 0xff000000
```



Link Layer

Network Interface and Hardware

- ❑ LAN (Local), WAN (Wide), MAN (Metropolitan)
 - Ethernet, Token-Ring, FDDI
 - PPP, xDSL, ISDN
- ❑ Physical Topologies (see next slide)
- ❑ Logical Topologies
 - Broadcast, Token-passing
- ❑ Common LAN Devices
 - NIC, Repeater, Hub, Bridge, Switch, Router
- ❑ Common LAN Media
 - UTP, STP, Coaxial Cable, Fiber Optic Cable

Network Interface and Hardware

– Physical Topologies

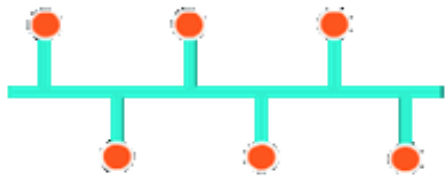

Bus

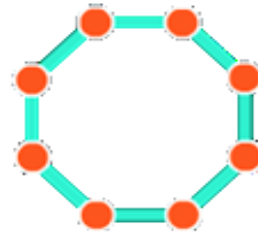

Ring

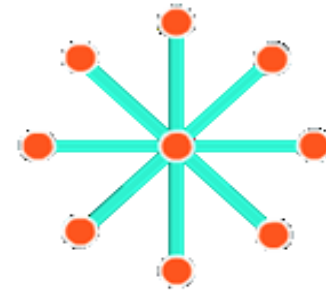

Star

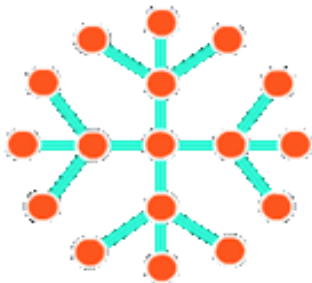

**Extended
Star**

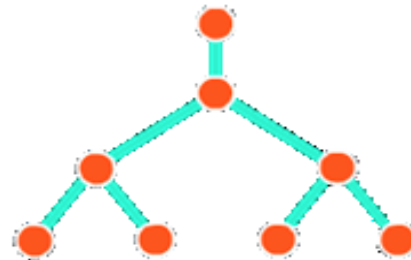

Hierarchical



Mesh

Network Interface and Hardware

– Media

□ Media

- Coaxial Cable
 - Thicknet v.s. thinnet
 - BNC connector
- Twisted Pair Standards

| Pin# | 1 | 2 | 3 | 4 | 5 | 6 | 7 | 8 |
|--------|-----|--------|-----|------|--------|--------|------|-------|
| T568-A | W/G | Green | W/O | Blue | W/Blue | Orange | W/Br | Brown |
| T568-B | W/O | Orange | W/G | Blue | W/Blue | Green | W/Br | Brown |

- Straight-through v.s. Crossover
 - RJ-45 connector
- Fiber Optic Cable
 - Multimode v.s. single mode
- Wireless
 - IrDA, Radio (2.4GHz, 5GHz)

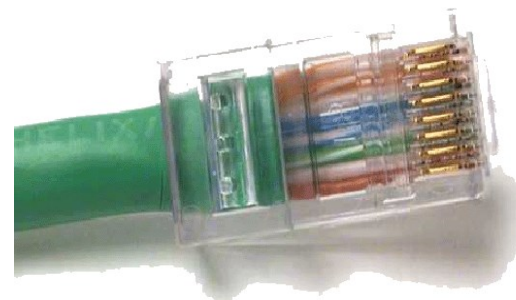
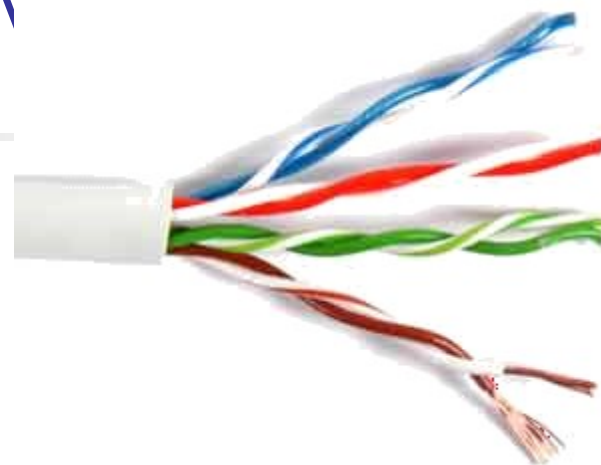

The Link Layer

- ❑ Ethernet: the common LAN
 - 10 Mb/s → 100 Mb/s → 1Gb/s
 - 802.3 → 802.3u → 802.3z
 - CSMA/CD (Carrier Sense Multiple Access/Collision Detect)
- ❑ Ethernet Address (48bits)
 - 00:80:c8:92:0e:e1
- ❑ Ethernet Frame
 - Ethernet MTU (Maximum Transmission Unit) is 1500 bytes
 - IP fragmentation
 - Path MTU
 - MTU of various physical device

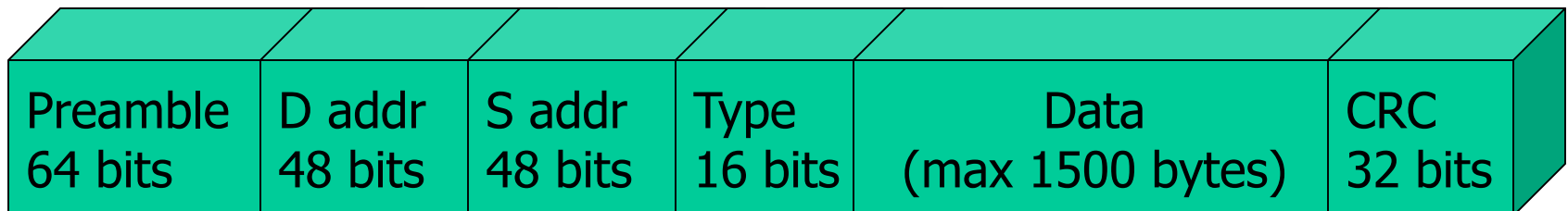



Network Layer

The Network Layer

❑ Path Determination

- The Internet Protocol (IP)
 - IP address (32 bits)

❑ Topics

- IP Address
- Subnetting and netmask
- Address types
- Routing

The Network Layer

– IP Address

❑ 32-bit long

- Network part
 - Identify a logical network
- Host part
 - Identify a machine on certain network

❑ Ex:

- NCTU
 - Class B address: 140.113.0.0
 - Network ID: 140.113
 - Number of hosts: $256 * 256 = 65536$

❑ IP address category

| Class | 1 st byte ^a | Format | Comments |
|-------|-----------------------------------|---------|--|
| A | 1-126 | N.H.H.H | Very early networks, or reserved for DOD |
| B | 128-191 | N.N.H.H | Large sites, usually subnetted, were hard to get |
| C | 192-223 | N.N.N.H | Easy to get, often obtained in sets |
| D | 224-239 | – | Multicast addresses, not permanently assigned |
| E | 240-254 | – | Experimental addresses |

a. The values 0 and 255 are special and are not used as the first byte of regular IP addresses. 127 is reserved for the loopback address.

The Network Layer

– Subnetting and Netmask (1)

❑ Subnetting

- Borrow some bits from network ID to extends hosts ID
- Ex:
 - ClassB address : 140.113.0.0
= 256 ClassC-like IP addresses
in N.N.N.H subnetting method
 - 140.113.209.0 subnet

❑ Netmask

- Specify how many bits of network-ID are used for network-ID
- Continuous 1 bits form the network part
- Ex:
 - 255.255.255.0 in NCTU-CS example
 - 256 hosts available
 - 255.255.255.248 in ADSL example
 - Only 8 hosts available

The Network Layer

– Subnetting and Netmask (2)

□ How to determine your network ID?

- Bitwise-AND IP and netmask
- Ex:
 - **140.113.214.37 & 255.255.255.0 → 140.113.214.0**
 - **140.113.209.37 & 255.255.255.0 → 140.113.209.0**

 - **140.113.214.37 & 255.255.0.0 → 140.113.0.0**
 - **140.113.209.37 & 255.255.0.0 → 140.113.0.0**

 - **211.23.188.78 & 255.255.255.248 → 211.23.188.72**
 - 78 = 01001110
 - 78 & 248 = 01001110 & 11111000 = 72

The Network Layer

– Subnetting and Netmask (3)

❑ In a subnet, not all IP are available

- The first one IP → network ID
- The last one IP → broadcast address

- Ex:

Netmask 255.255.255.0
140.113.209.32/24

140.113.209.0 → network ID
140.113.209.255 → broadcast address
1 ~ 254, total 254 IPs are usable

Netmask 255.255.255.252
211.23.188.78/29

211.23.188.72 → network ID
211.23.188.79 → broadcast address
73 ~ 78, total 6 IPs are usable

The Network Layer

– Subnetting and Netmask (4)

❑ The smallest subnetting

- Network portion : 30 bits
- Host portion : 2 bits
- ➔ 4 hosts, but only 2 IPs are available

❑ ipcalc

- /usr/ports/net-mgmt/ipcalc

```

chbsd [/usr/ports/net-mgmt/ipcalc] -chwong- ipcalc 140.113.209.78/28
Address: 140.113.209.78      10001100.01110001.11010001.0100 1110
Netmask: 255.255.255.240 = 28 11111111.11111111.11111111.1111 0000
Wildcard: 0.0.0.15          00000000.00000000.00000000.0000 1111
=>
Network: 140.113.209.64/28   10001100.01110001.11010001.0100 0000
HostMin: 140.113.209.65     10001100.01110001.11010001.0100 0001
HostMax: 140.113.209.78     10001100.01110001.11010001.0100 1110
Broadcast: 140.113.209.79   10001100.01110001.11010001.0100 1111
Hosts/Net: 14                Class B

```

The Network Layer

– Subnetting and Netmask (5)

- Network configuration for various lengths of netmask

| Length ^a | Host bits | Hosts/net ^b | Dec. netmask | Hex netmask |
|---------------------|-----------|------------------------|-----------------|-------------|
| /20 | 12 | 4094 | 255.255.240.0 | 0xFFFFF000 |
| /21 | 11 | 2046 | 255.255.248.0 | 0xFFFFF800 |
| /22 | 10 | 1022 | 255.255.252.0 | 0xFFFFFC00 |
| /23 | 9 | 510 | 255.255.254.0 | 0xFFFFFE00 |
| /24 | 8 | 254 | 255.255.255.0 | 0xFFFFF000 |
| /25 | 7 | 126 | 255.255.255.128 | 0xFFFFF800 |
| /26 | 6 | 62 | 255.255.255.192 | 0xFFFFFC00 |
| /27 | 5 | 30 | 255.255.255.224 | 0xFFFFFE00 |
| /28 | 4 | 14 | 255.255.255.240 | 0xFFFFF000 |
| /29 | 3 | 6 | 255.255.255.248 | 0xFFFFF800 |
| /30 | 2 | 2 | 255.255.255.252 | 0xFFFFFC00 |

The Network Layer

— IP address crisis

❑ IP address crisis

- Run out of class B address
 - The most desirable ones for moderately large organizations
- IP address were being allocated on a FCFS
 - With no locality of reference

❑ Solutions

- Short term
 - Subnetting and CIDR (classless inter-domain routing)
 - NAT (network address translation)
- Long term
 - IPv6

The Network Layer

– NAT (1)

❑ Private Address

- Packets that bearing private address will not go out to the Internet
- 3 private addresses range
 - Depend on the size of your organization

| IP class | From | To | CIDR range |
|----------|-------------|-----------------|----------------|
| Class A | 10.0.0.0 | 10.255.255.255 | 10.0.0.0/8 |
| Class B | 172.16.0.0 | 172.31.255.255 | 172.16.0.0/12 |
| Class C | 192.168.0.0 | 192.168.255.255 | 192.168.0.0/16 |

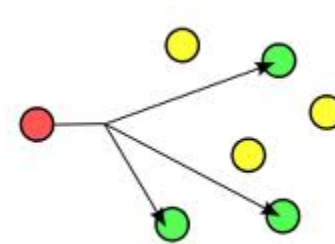
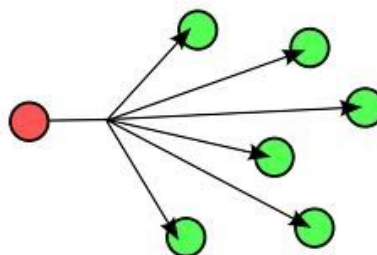
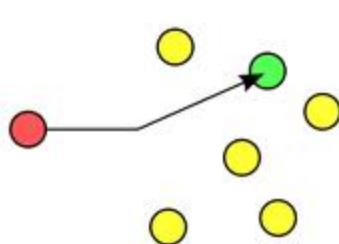

The Network Layer

– NAT (2)

- NAT
 - Network Address Translation
 - Allow hosts using private address to talk with outside

NAT mapping table

| Orig | Alias | Remote |
|------------------|----------------------|--------------------|
| 192.168.1.1:1029 | 140.116.72.219:1029 | ↔ 140.116.72.72:23 |
| 192.168.1.1:1030 | 140.116.72.219:1030 | ↔ 140.116.72.72:23 |
| 192.168.1.2:1029 | 140.116.72.219:30029 | ↔ 140.116.72.72:21 |
| 192.168.1.2:1030 | 140.116.72.219:30030 | ↔ 140.116.72.72:21 |

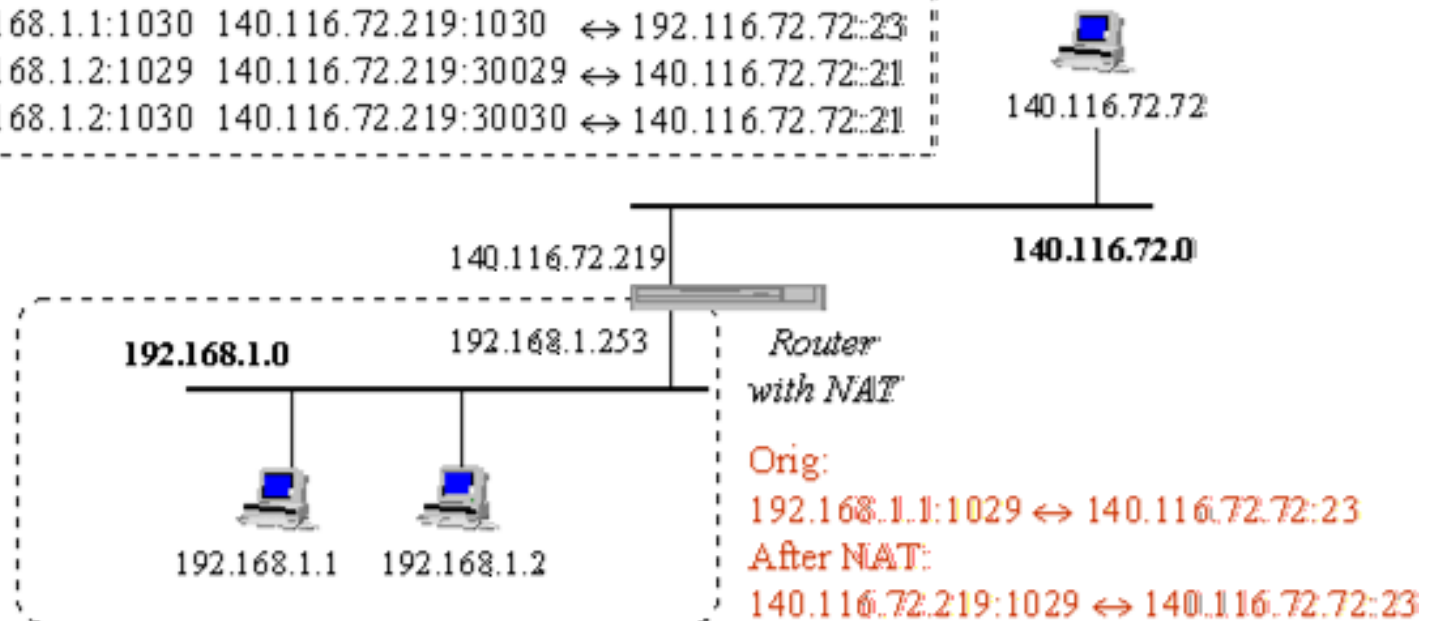

The Network Layer

– Routing (1)

- ❑ Goal: Direct a packet closer to the destination
- ❑ Flat v.s. Hierarchical
- ❑ Routing table
 - Routing information (which kind of packets to which way)
 - Rule-based information
 - Kernel will pick the most suitable way to route the packets

```
chbsd [/home/chwong] -chwong- netstat -rn
Routing tables
```

```
Internet:
```

| Destination | Gateway | Flags | Refs | Use | Netif | Expire |
|----------------|-----------------------|-------|------|---------|-------|--------|
| default | 140.113.17.254 | UGS | 0 | 4439610 | dc0 | |
| 127.0.0.1 | 127.0.0.1 | UH | 0 | 3887 | lo0 | |
| 140.113.17/24 | link#1 | UC | 0 | 0 | dc0 | |
| 140.113.17.209 | 00:0d:61:21:02:54 | UHLW | 1 | 38 | dc0 | 477 |
| 140.113.17.212 | 00:90:96:23:8f:7d | UHLW | 1 | 22558 | lo0 | |
| 140.113.17.215 | 00:11:d8:06:1e:81 | UHLW | 1 | 17 | dc0 | 1188 |
| 140.113.17.248 | 00:0b:ac:d7:93:40 | UHLW | 1 | 0 | dc0 | 1170 |
| 140.113.17.254 | 00:90:69:64:ec:00 | UHLW | 2 | 0 | dc0 | 1200 |

The Network Layer

– Routing (2)

❑ Static route

- Statically configured by “route” command
- Ex:
 - % route add default 140.113.235.254
 - % route add 192.168.1.0/24 192.168.1.254

❑ Dynamic route

- gated

The Network Layer

– Routing (3)

□ “ping -R” and “traceroute”

```
chbsd [/home/chwong] -chwong- ping -c 1 -R www.nctu.edu.tw
PING www.nctu.edu.tw (140.113.250.5): 56 data bytes
64 bytes from 140.113.250.5: icmp_seq=0 ttl=61 time=2.249 ms
RR:   ProjE27-253.NCTU.edu.tw (140.113.27.253)
      140.113.0.57
      CC250-gw.NCTU.edu.tw (140.113.250.253)
      www.NCTU.edu.tw (140.113.250.5)
      www.NCTU.edu.tw (140.113.250.5)
      140.113.0.58
      ProjE27-254.NCTU.edu.tw (140.113.27.254)
      e3rtn.csie.nctu.edu.tw (140.113.17.254)
      chbsd.csie.nctu.edu.tw (140.113.17.212)
```

--- www.nctu.edu.tw ping statistics ---

1 packets transmitted, 1 packets received, 0% packet loss
round-trip min/avg/max/stddev = 2.249/2.249/2.249/0.000 ms

```
chbsd [/home/chwong] -chwong- traceroute www.nctu.edu.tw
traceroute to www.nctu.edu.tw (140.113.250.5), 64 hops max, 40 byte packets
 1 e3rtn (140.113.17.254) 0.524 ms 0.406 ms 0.512 ms
 2 ProjE27-254.NCTU.edu.tw (140.113.27.254) 0.574 ms 0.501 ms 0.422 ms
 3 140.113.0.58 (140.113.0.58) 0.487 ms 0.583 ms 0.541 ms
 4 www.NCTU.edu.tw (140.113.250.5) 0.673 ms 0.611 ms 0.621 ms
```



Transport Layer

The Transport Layer

– ports

- ❑ 16-bits number
- ❑ Preserve ports
 - 1 ~ 1024 (root access only)
- ❑ Well-known port
 - /etc/services

```
...
chargen      19/tcp      ttytst source      #Character Generator
chargen      19/udp      ttytst source      #Character Generator
ftp-data     20/tcp      #File Transfer [Default Data]
ftp-data     20/udp      #File Transfer [Default Data]
ftp          21/tcp      #File Transfer [Control]
ftp          21/udp      #File Transfer [Control]
ssh          22/tcp      #Secure Shell Login
ssh          22/udp      #Secure Shell Login
telnet       23/tcp
telnet       23/udp
...
```

- IANA Service Name and Transport Protocol Port Number Registry
 - <https://www.iana.org/assignments/service-names-port-numbers>

The Transport Layer

□ UDP v.s. TCP

| Function | UDP | TCP |
|--------------------------|----------|-----|
| Connection-oriented | No | Yes |
| Message boundaries | Yes | No |
| Data checksum | Optional | Yes |
| Positive acknowledgement | No | Yes |
| Time-out and retransmit | No | Yes |
| Duplicate detection | No | Yes |
| Sequencing | No | Yes |
| Flow control | No | Yes |

The Transport Layer

– useful commands

❑ tcpdump, sniffit, trafshow, netstat -s

```
chbsd [/home/chwong] -chwong- sudo tcpdump -n host 140.113.235.131
tcpdump: verbose output suppressed, use -v or -vv for full protocol decode
listening on dc0, link-type EN10MB (Ethernet), capture size 96 bytes
11:25:50.996542 IP 140.113.17.212.61233 > 140.113.235.131.22: P 266166194:266166226(32)
ack 938637316 win 33304 <nop,nop,timestamp 3368918203 130908112>
11:25:50.998247 IP 140.113.235.131.22 > 140.113.17.212.61233: P 1:33(32) ack 32 win 33304
<nop,nop,timestamp 134993614 3368918203>
11:25:50.998396 IP 140.113.235.131.22 > 140.113.17.212.61233: P 33:65(32) ack 32 win 33304
<nop,nop,timestamp 134993614 3368918203>
11:25:50.998438 IP 140.113.17.212.61233 > 140.113.235.131.22: . ack 65 win 33288
<nop,nop,timestamp 3368918205 134993614>
11:26:36.935422 IP 140.113.17.212 > 140.113.235.131: ICMP echo request, id 28124, seq 0,
length 64
11:26:36.935761 IP 140.113.235.131 > 140.113.17.212: ICMP echo reply, id 28124, seq 0,
length 64
^C
6 packets captured
697 packets received by filter
0 packets dropped by kernel
```

The Application Layer

❑ The Client-Server Model

- Port Numbers:
 - /etc/services
 - The first 1024 ports are reserved ports
- Internet Services
 - inetd and /etc/inetd.conf
- DNS

The Application Layer

– inetd

□ inetd – internet “super-server”

- add `inetd_enable="YES"` into `/etc/rc.conf`
- `/etc/inetd.conf`

```
daytime  stream tcp  nowait root  internal
ftp      stream tcp  nowait root  /usr/libexec/ftpd  ftpd -l
ssh     stream tcp  nowait root  /usr/sbin/sshd    sshd -i -4
telnet  stream tcp  nowait root  /usr/libexec/telnetd telnetd
pop3    stream tcp  nowait root  /usr/local/libexec/popper  popper
```

- `/etc/services`

```
daytime  13/tcp
ftp-data 20/tcp  #File Transfer [Default Data]
ftp      21/tcp  #File Transfer [Control]
ssh     22/tcp  #Secure Shell Login
telnet  23/tcp
pop3    110/tcp #Post Office Protocol - Version 3
```

The Application Layer

– DNS

□ Domain Name System

- Record IP-hostname mapping
- DNS query
 - “what is the IP of vangogh.cs.berkeley.edu” from lair.cs.colorado.edu
- Hierarchical architecture

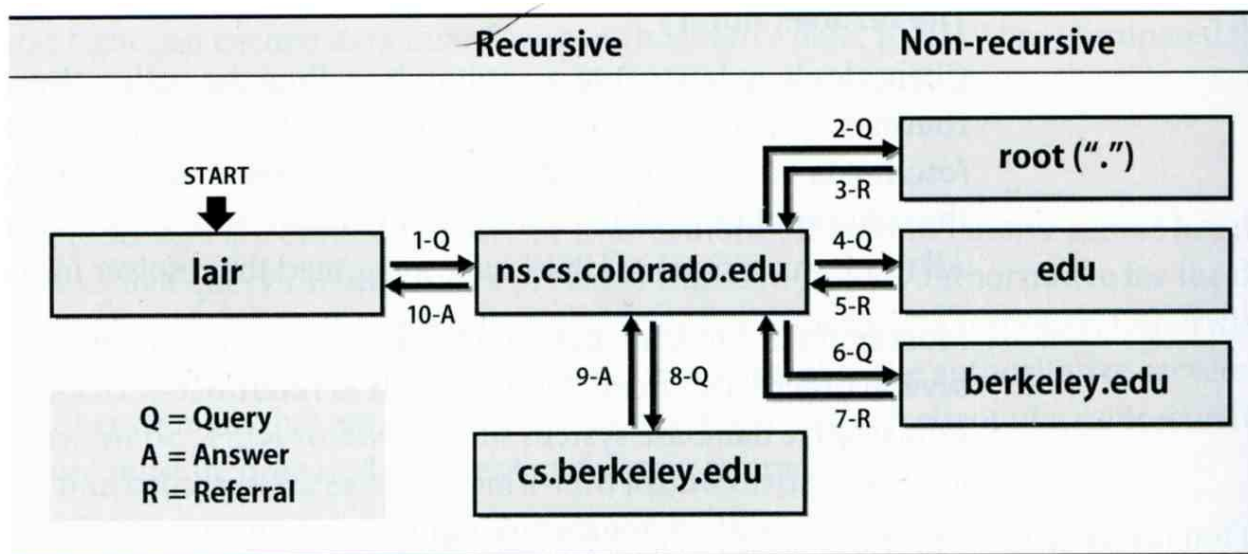

ARP (1)

❑ Address Resolution Protocol

- Ask MAC address of certain IP
- Broadcast
- Any one receiving ARP packet and having this IP will reply to the sender
- When the host owing this IP is not on the same network, sender will use the MAC address of next-hop router to send the packet

ARP (2)

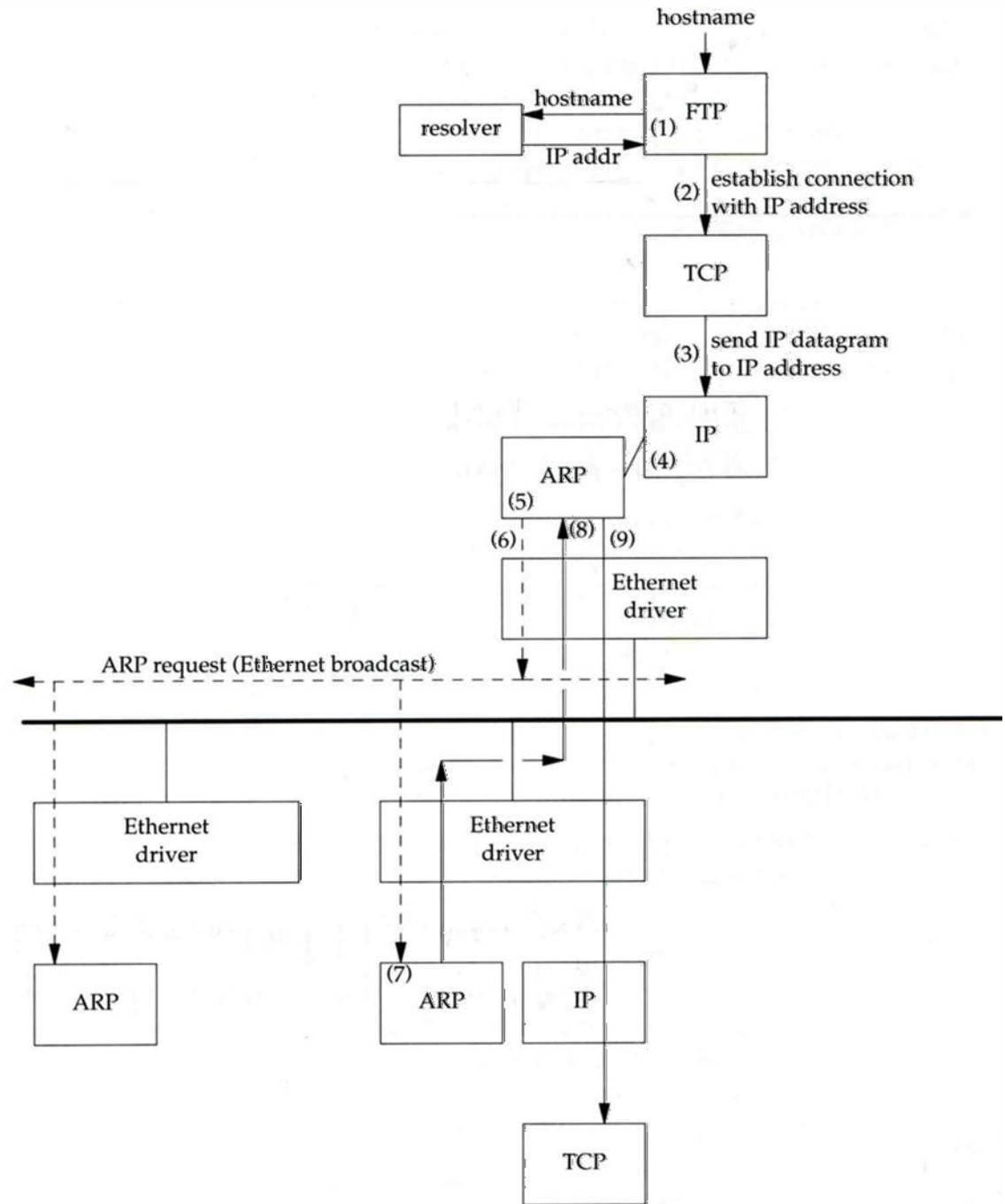

ARP (3)

□ Maintain recent ARP results

- come from both ARP request and reply
- expiration time
 - Complete entry = 20 minutes
 - Incomplete entry = 3 minutes
- Use arp command to see the cache
- Ex:
 - % arp -a
 - % arp -da

```
[chwong@mg-215]~> arp -a
crypto23.csie.nctu.edu.tw (140.113.208.143) at 00:16:e6:5b:fa:e9 on fxp1 [ethernet]
e3rtn-208.csie.nctu.edu.tw (140.113.208.254) at 00:0e:38:a4:c2:00 on fxp1 [ethernet]
e3rtn-210.csie.nctu.edu.tw (140.113.210.254) at 00:0e:38:a4:c2:00 on fxp2 [ethernet]
winpc7.csie.nctu.edu.tw (140.113.215.187) at 00:17:31:84:6c:0f on fxp3 [ethernet]
e3rtn-215.csie.nctu.edu.tw (140.113.215.254) at 00:0e:38:a4:c2:00 on fxp3 [ethernet]
e3rtn-216.csie.nctu.edu.tw (140.113.216.254) at 00:0e:38:a4:c2:00 on fxp0 [ethernet]
```

Setup network connection

□ Steps

- Assign an IP address and hostname
- Default route
- DNS
- Utility to test whether you connect to the Internet

Setup network connection

– assign IP, hostname and default route (1)

❑ FreeBSD

- In /etc/rc.conf

```
defaultrouter="140.113.17.254"  
hostname="chbsd.csie.nctu.edu.tw"  
ifconfig_fxp0="inet 140.113.17.212 netmask 255.255.255.0"  
ifconfig_fxp0_alias0="inet 140.113.17.214 netmask 255.255.255.255"  
ifconfig_fxp1="inet 192.168.1.254 netmask 255.255.255.0"
```

❑ Linux

- /etc/sysconfig/network
- /etc/sysconfig/network-scripts/ifcfg-eth0

```
NETWORKING=yes  
HOSTNAME=linux3  
GATEWAY=140.113.209.254
```

```
DEVICE=eth0  
BOOTPROTO=static  
BROADCAST=140.113.209.255  
IPADDR=140.113.209.143  
NETMASK=255.255.255.0  
NETWORK=140.113.209.0  
ONBOOT=yes
```

Setup network connection

– assign IP, hostname and default route (2)

❑ /etc/hosts

- Host name database
- Each line is a host
 - Internet address
 - Official host name
 - aliases

```
chwong@qkmj:~> less /etc/hosts
127.0.0.1      localhost
140.113.209.72 cbsd12 cbsd12.csie.nctu.edu.tw
140.113.209.2  ccserv
140.113.209.6  ccduty
140.113.209.7  mailgate
140.113.209.32 qkmj
```

Setup network connection

– assign IP, hostname and default route (3)

☐ Solaris

- /etc/inet/netmasks (network and netmask)
- /etc/inet/hosts (hosts)
- /etc/defaultrouter (default router)
- /etc/nodename (host name)
- /etc/resolv.conf (domain, nameserver, search)
- /etc/hostname.*interface* (IP, either hostname in hosts or IP)

```
sun1 [/etc] -chwong- cat hostname.rtlis0 nodename defaultrouter resolv.conf
sun1
sun1.cs.nctu.edu.tw
140.113.235.254
domain cs.nctu.edu.tw
nameserver 140.113.235.107
nameserver 140.113.6.2
sun1 [/etc] -chwong- cat /etc/inet/netmasks /etc/inet/hosts
140.113.235.0    255.255.255.0
127.0.0.1      localhost
140.113.235.102 csduty
140.113.235.171 sun1
140.113.235.101 cshome
```

Setup network connection

– assign IP, hostname and default route (4)

❑ Change IP manually

• Ex:

- **% ifconfig fxp0 inet 140.113.235.4 netmask 255.255.255.0**
- **% ifconfig fxp0 up**
- **% ifconfig fxp0 down**

❑ Specify default route manually

• Ex:

- **% route add default 140.113.235.254**

Setup network connection

– configuring DNS

❑ FreeBSD, Linux

- /etc/resolv.conf

```
chbsd [/etc] -chwong- cat resolv.conf
domain cs.nctu.edu.tw
nameserver 140.113.235.107
search cs.nctu.edu.tw csie.nctu.edu.tw nctu.edu.tw
```

❑ Host lookup order

- FreeBSD, Linux
 - /etc/nsswitch.conf

```
chbsd [/etc] -chwong- cat nsswitch.conf
group: compat
group_compat: nis
hosts: files dns
networks: files
passwd: compat
passwd_compat: nis
shells: files
services: compat
services_compat: nis
protocols: files
rpc: files
```

Utilities for network connection

❑ ping

- Send ICMP ECHO_REQUEST to a host

```
chbsd [/etc] -chwong- ping -c 1 www.nctu.edu.tw
PING www.nctu.edu.tw (140.113.250.5): 56 data bytes
64 bytes from 140.113.250.5: icmp_seq=0 ttl=60 time=3.022 ms

--- www.nctu.edu.tw ping statistics ---
1 packets transmitted, 1 packets received, 0% packet loss
round-trip min/avg/max/stddev = 3.022/3.022/3.022/0.000 ms
```

❑ traceroute

- Print the route packets take to network host

```
chbsd [/etc] -chwong- traceroute www.nctu.edu.tw
traceroute to www.nctu.edu.tw (140.113.250.5), 64 hops max, 40 byte packets
 1 e3rtn-235 (140.113.235.254) 0.640 ms 0.449 ms 0.474 ms
 2 140.113.0.210 (140.113.0.210) 0.465 ms 0.310 ms 0.361 ms
 3 140.113.0.166 (140.113.0.166) 0.415 ms 0.379 ms 0.403 ms
 4 140.113.0.149 (140.113.0.149) 0.678 ms 0.536 ms 0.574 ms
 5 www.NCTU.edu.tw (140.113.250.5) 0.533 ms 0.415 ms 0.438 ms
```

Useful Utilities in ports

- ❑ net/mtr
 - Traceroute and ping in a single graphical network diagnostic tool
- ❑ net/nload
 - Console application which monitors network traffic in real time
- ❑ net/wireshark
- ❑ net/tshark
 - A powerful network analyzer/capture tool

Other issues

- ❑ The following issues will be given in NA (Network Administration)
 - DHCP
 - PPP
 - NAT
 - DNS
 - Mail
 - ...