

Wireless Communication Systems

@CS.NCTU

Lecture 5: Rate Adaptation

Instructor: Kate Ching-Ju Lin (林靖茹)

PSK and QAM

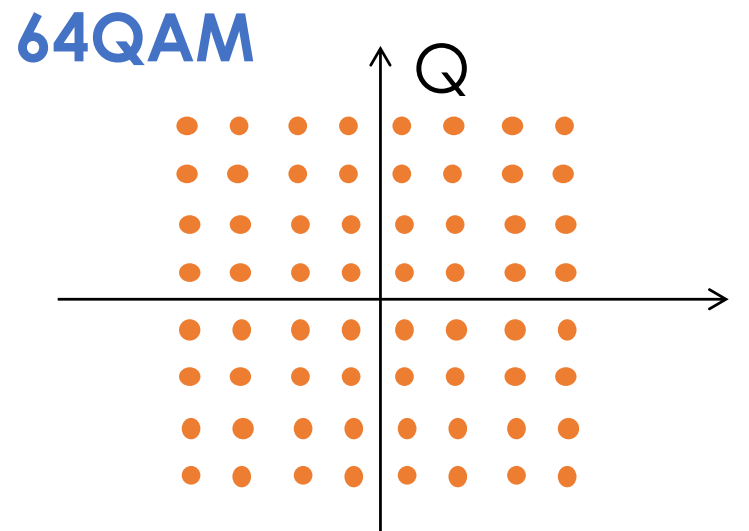
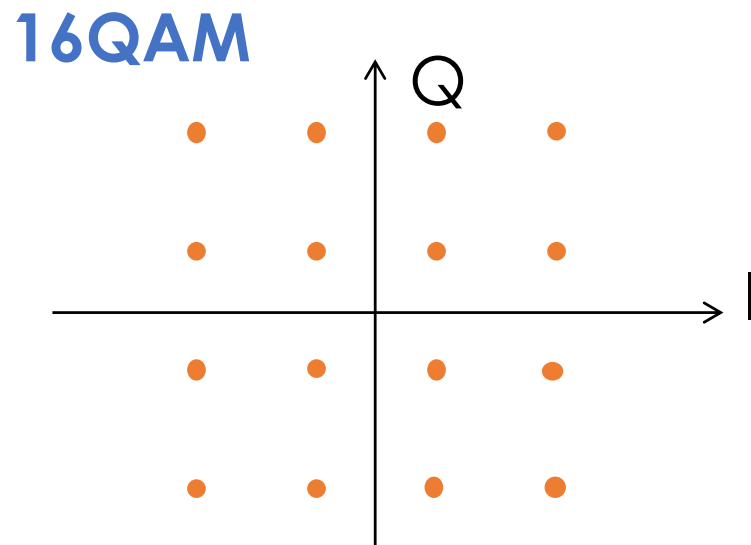
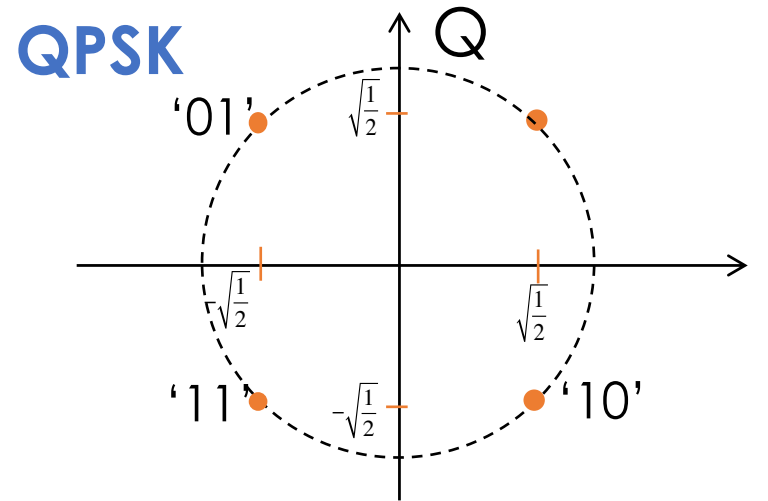
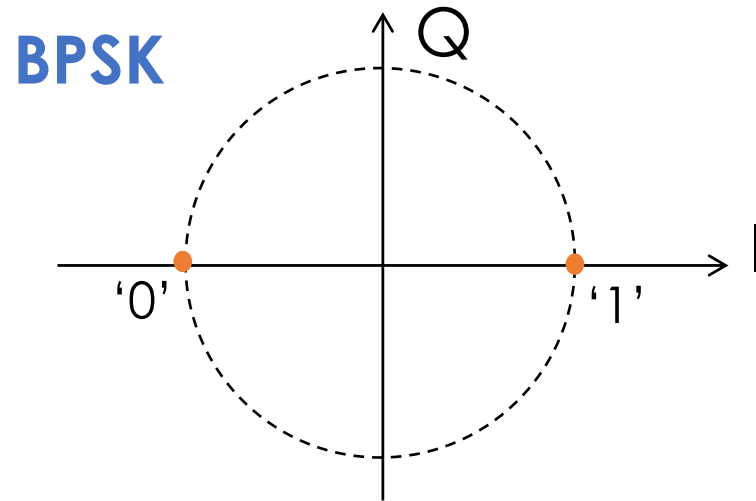

Agenda

- What is bit-rate adaptation?
- What are the challenges?
- Receiver-based bit-rate adaptation
- Transmitter-based bit-rate adaptation
- Bit-rate adaptation for multicast

Bit-Rates in 802.11

Bit-rate	802.11 Standards	DSSS or OFDM	Modulation	Bits per Symbol	Coding Rate	Mega-Symbols per second
1	b	DSSS	BPSK	1	1/11	11
2	b	DSSS	QPSK	2	1/11	11
5.5	b	DSSS	CCK	1	4/8	11
11	b	DSSS	CCK	2	4/8	11
6	a/g	OFDM	BPSK	1	1/2	12
9	a/g	OFDM	BPSK	1	3/4	12
12	a/g	OFDM	QPSK	2	1/2	12
18	a/g	OFDM	QPSK	2	3/4	12
24	a/g	OFDM	QAM-16	4	1/2	12
36	a/g	OFDM	QAM-16	4	3/4	12
48	a/g	OFDM	QAM-64	6	2/3	12
54	a/g	OFDM	QAM-64	6	3/4	12

Coding Rate

- Avoid random errors
 - 1/2: Add 1x redundant bits
 - 3/4: Add 1/3x redundant bits
- Haven't solved the problem yet
 - Data input: 1, 1, 0, 1, 0, 1, 1, 0, ...
 - After encoding:
1, 1, 1, 1, 0, 0,  1, 0, 1, 1, 1, 1, 0, 0,
 - Still one bit error → Suffer from burst errors

Interleave and De-interleave

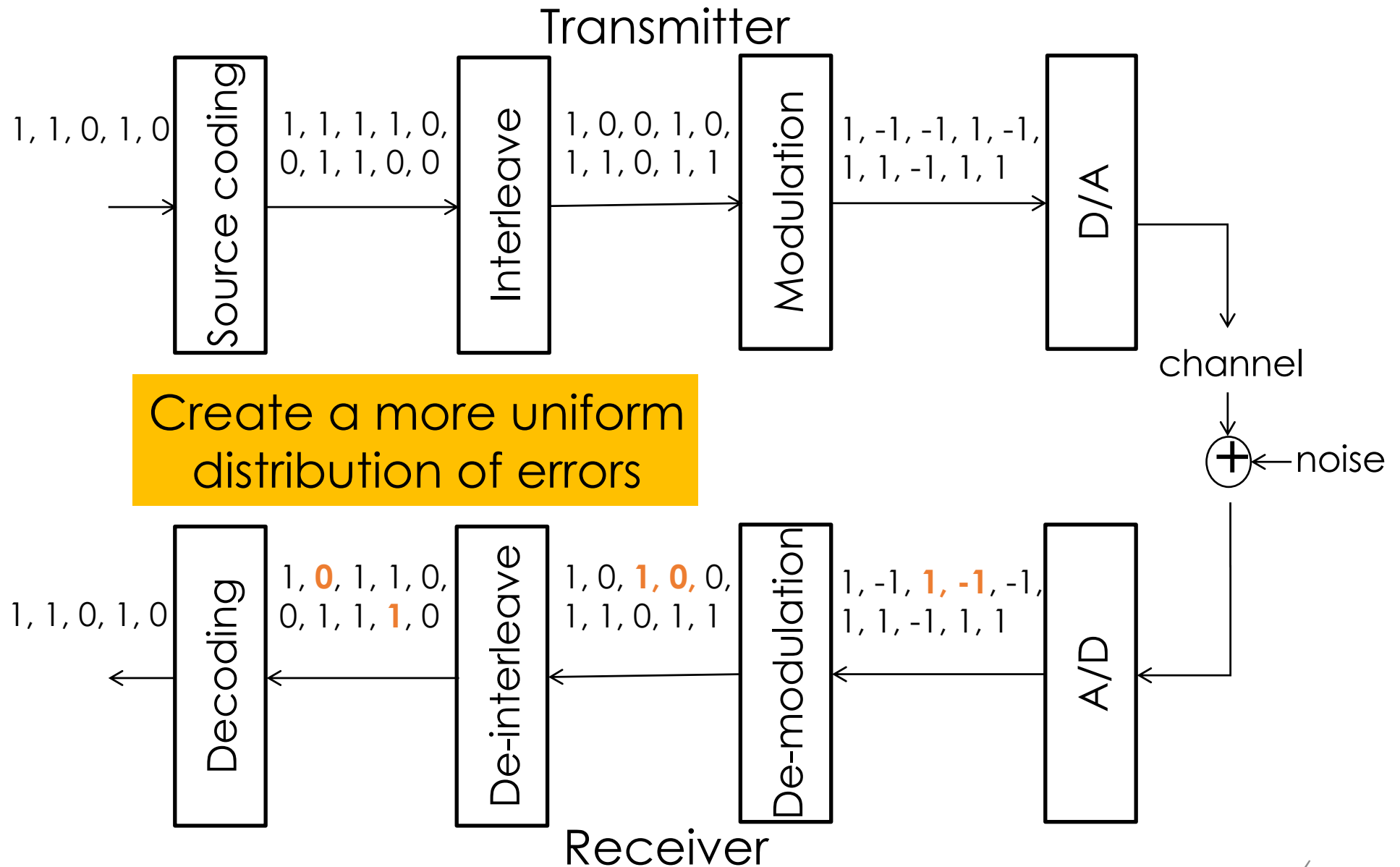

Channel Quality vs. Bit-Rate

- When channels are very good
 - Encode more digital bits as a symbol
- When channels are noisy
 - Encode fewer data bits as a sample

Why is it affected by the channel quality?

Error Probability vs. Modulations

Given the same SNR

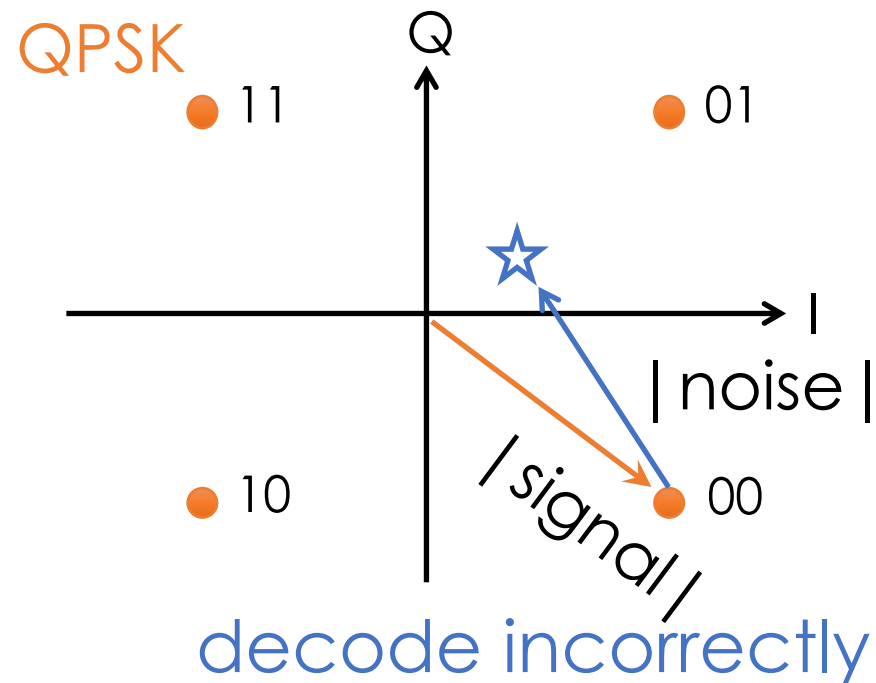
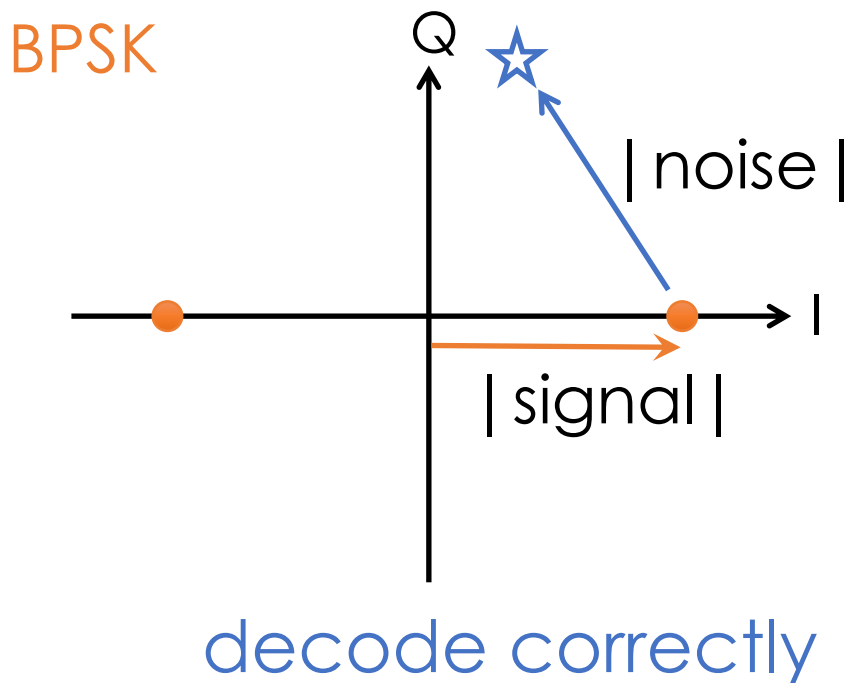

$$\text{SNR} = 10 \log_{10} (|\text{signal}|^2 / |\text{noise}|^2)$$

Given the same SNR, decodable for BPSK,
but un-decodable for QPSK

SNR vs. BER (Bit Error Rate)

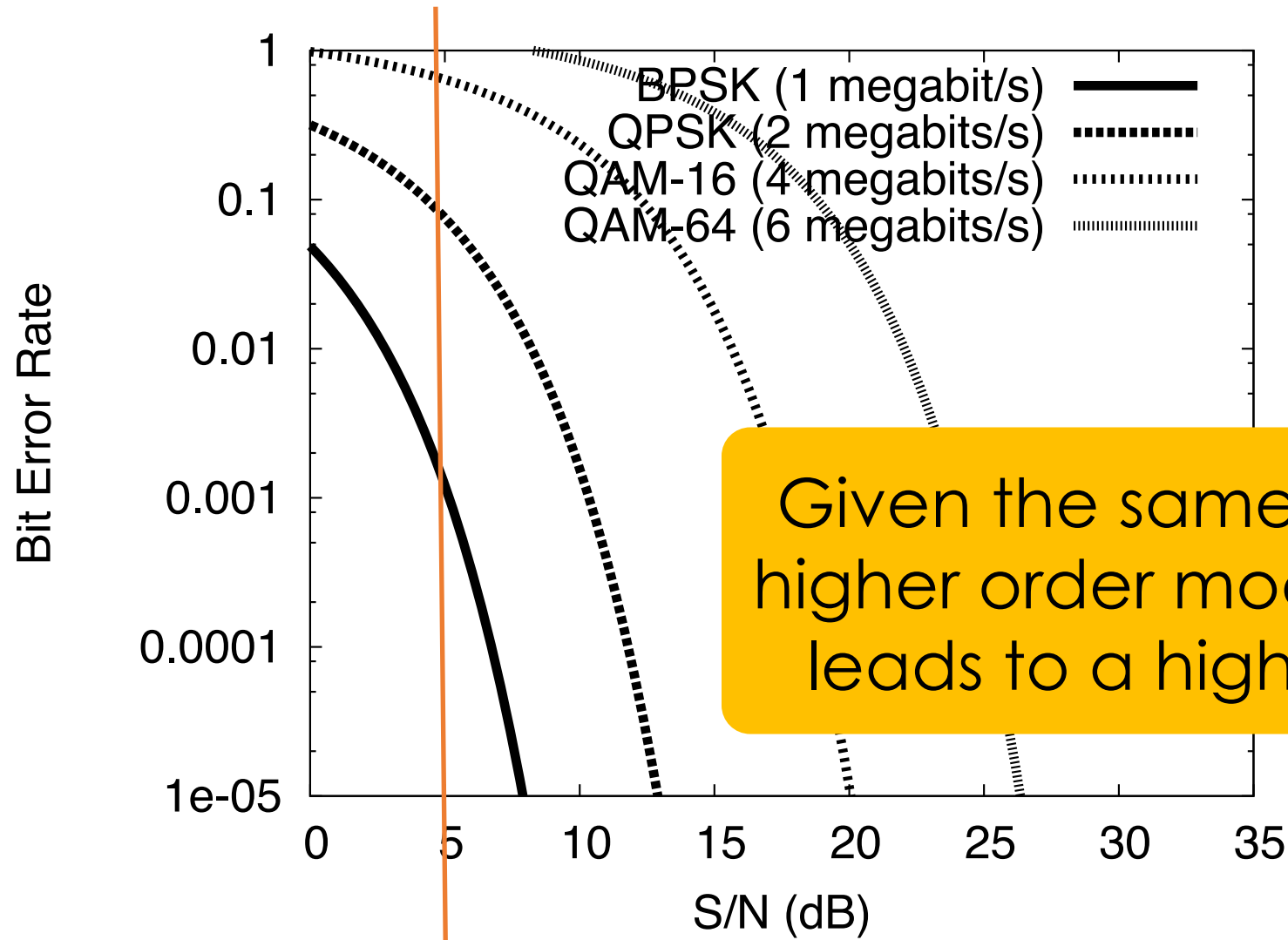

802.11 operating region 5dB

SNR vs. PDR (Packet Delivery Ratio)

- In 802.11, a packet is received correctly if it passes the CRC check (all bits are correct)
 - Receive **all** or **none**
- Given an SNR value, BER and PDR change with bit-rates

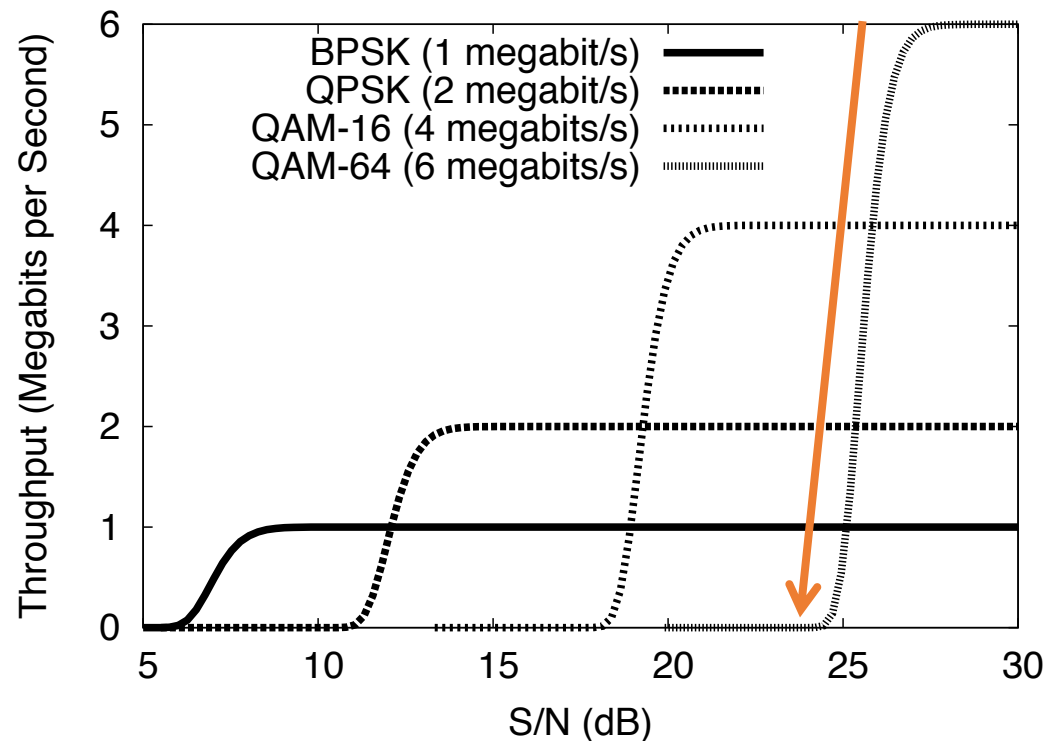

$$\text{PDR}(r) = (1 - \text{BER}(r))^n$$

$$\begin{aligned} \text{Throughput}(r) \\ &= \text{PDR}(r) * r \end{aligned}$$

Throughput degrades quickly even with a small BER

Bit-Rate Selection

- Given the SNR, select the optimal bit-rate that achieves the highest throughput

$$r^* = \arg \min_r \text{PDR}(r) * r$$

Ideal case without considering the protocol overhead

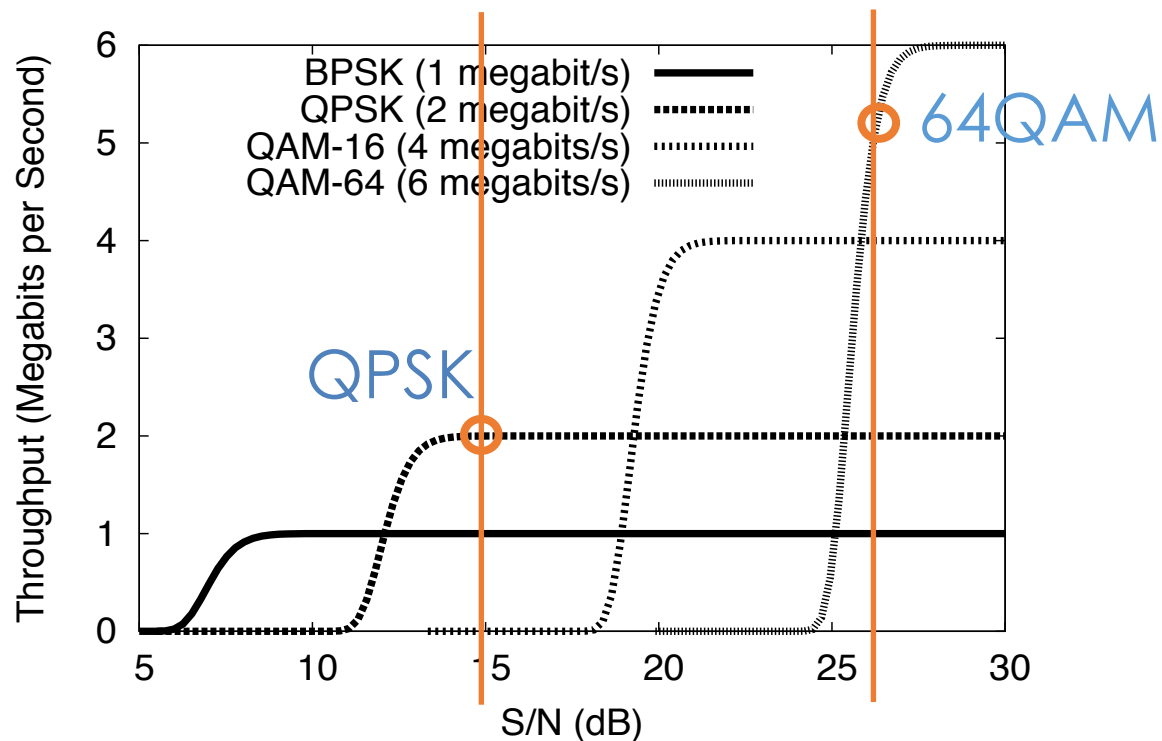

Difficulties with Rate Adaptation

- Channel quality changes very quickly
 - Especially when the device is moving
- Can't tell the difference between
 - poor channel quality due to **noise/interference/collision** (high | noise |)
 - poor channel quality due to **long distance** (low | signal |)

Ideally, we want to decrease the rate due to low signal strength, but not interference/collisions

Types of Auto-Rate Adaptation

	Transmitter-based	Receiver-Based
SNR-based		RBAR, OAR, ESNR
ACK-based	ARF, AARF, ONOE	
Throughput-based	SampleRate, RRAA	
Partial packet		ZipTx
Soft information		SoftRate

Sync. ACK vs. Async ACK

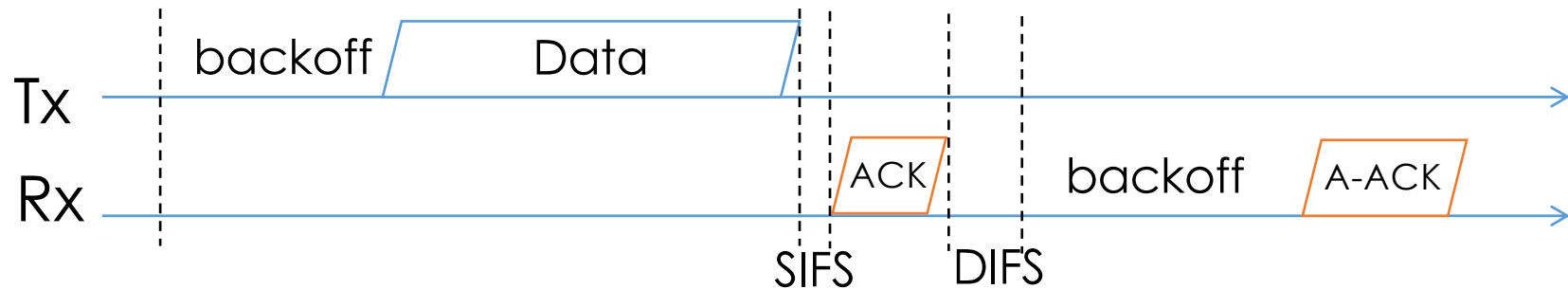

- **Synchronous ACK**
 - Sent **immediately** after SIFS as a control frame (defined in 802.11)
 - Cost the **minimum overhead**
 - Only know whether the packet is transmitted correctly
- **Asynchronous ACK**
 - Sent as a data frame
 - Cost additional overhead
 - Can include **more detailed information** (e.g., error rate)

Types of Auto-Rate Adaptation

	Transmitter-based	Receiver-Based
SNR-based		RBAR, OAR, ESNR
ACK-based	ARF, AARF, ONOE	
Throughput-based	SampleRate, RRAA	
Partial packet		ZipTx
Soft information		SoftRate

Properties	Selected by Tx	Selected by Rx
	Sync. ACK	Async. ACK
	Less accurate	Higher overhead

Rx-based Adaptation

- Receiver Based Auto Rate (RBAR)
 - The receiver measures the SNR of the RTS, and picks the optimal rate based on the SNR-to-rate lookup table
 - Piggyback the selected rate in CTS
- Opportunistic Auto Rate (OAR)
 - Similar to RBAR, but consider the channel coherence time
 - If the channel is good, opportunistically send more packets since the channel time of each frame is short
- Pros
 - More accurate since the Rx can measure the up-to-date channel condition
- Cons
 - Rely on asynchronous ACK, causing a higher overhead

Tx-based Adaptation

- **SampleRate**
 - Default in Linux
- **RRAA**
 - Robust Rate Adaption Algorithm
- **In common**
 - Probe the packets at a rate not used currently
 - See if switching to another rate gives a higher throughput
- **Differences**
 - Switch the rate by estimating the effective throughput
 - Switch the rate by measuring the packet loss rate

SampleRate – Tx-based Adaptation

- Default in Linux
- Periodically send packets at a **randomly-sampled bit-rate other than the current bit-rate**
 - Let r^* be the current best rate
 - After sending 10 packets at the best rate, send a packet at a **randomly-sampled** rate
 - Estimate the achievable throughput of the **sampled** rates

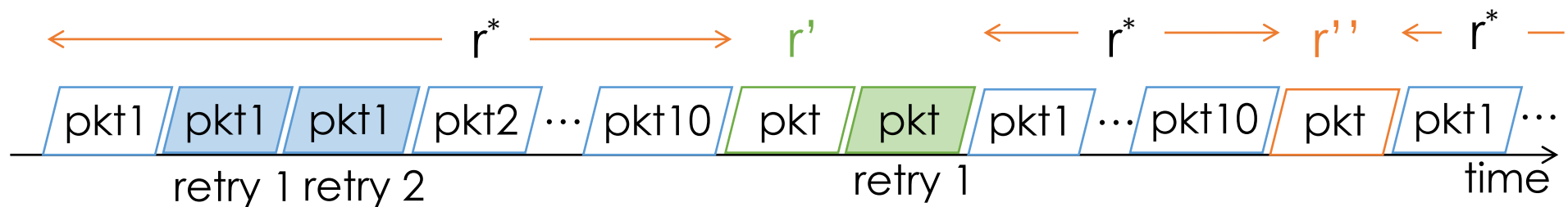

SampleRate – Throughput Estimation

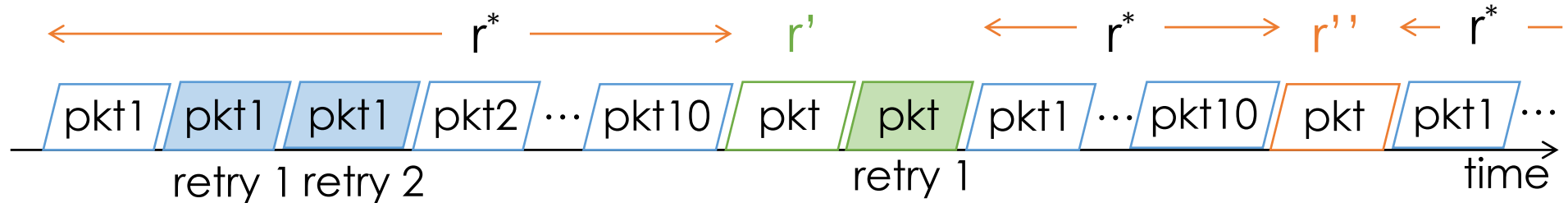

- How to estimate the effective throughput of a rate?
 - Calculate the transmission time of a L-bit packet
 - Consider packet length (l), bit-rate (r), number of retries (n), backoff time

$$T_{tx}(r, n, l) = T_{\text{DIFS}} + T_{\text{back off}}(n) + (n + 1)(T_{\text{SIFS}} + T_{\text{ACK}} + T_{\text{header}} + l/r)$$

- Select the rate that has the smallest measured average transmission time to deliver a L-bit packet

$$r^* = \min_r T_{tx}(r, n, L)$$

SampleRate

- Do not sample the rates that
 - Have failed four successive times
 - Are unlikely to be better than the current one
- Is thought of the most efficient scheme for **static environments**
 - SNR, and thereby BER and best rate, do not change rapidly over time
- Waste channel time for sampling if the channel is very stable

RRAA – Tx-based Adaptation

- Robust Rate Adaption Algorithm
- Root causes of packet failures
 - **Channel fading**: mainly determined by the link distance
 - **Random events**: collisions, cross-technique interference (e.g., bluetooth or microwave)
- Goal
 - **Robust against random loss**: Should not switch the rate due to random channel variation
 - **Responsive to drastic channel changes**: Should respond quickly to significant channel changes

S. Wong, H. Yang, S. Lu, V. Bharghavan, “Robust Rate Adaptation for 802.11 Wireless Networks,” ACM MOBICOM, 2006

RRAA

- Use **short-term loss ratio** to assess the channel
 - Probe a window of N frames at a bit-rate
 - Estimate the loss ratio

$$P = \frac{\# \text{ lost frames}}{\# \text{ transmitted frame}}$$

How to set
 P_{\min} , P_{\max} , N ?

- Stay unchanged if the loss ratio is acceptable
 - $P_{\min} < P < P_{\max}$
- Switch the rate to
 - A higher one if $P < P_{\min}$: imply that the channel is good enough to try the higher rate
 - A lower one if $P > P_{\max}$: imply that the channel is too bad to use the current rate

RRAA – Parameter Configuration

- P_{\max}^r : Maximum tolerable loss threshold
 - the effective throughput of the current rate should be no worse than the loss-free throughput at a lower rate

$$(1 - P_{\max}^r) \frac{l}{T_{rx}(r, n, l)} = \frac{l}{T_{rx}(r-1, n=1, l)}$$
$$\Rightarrow P_{\max}^r = 1 - \frac{T_{rx}(r, n, l)}{T_{rx}(r-1, n=1, l)}$$

- P_{\min}^r : Opportunistic rate Increase threshold
 - Harder to predict because we do not know how good is good enough
 - Heuristic: $P_{\min}^r = P_{\max}^{r+1} / \beta, \beta = 2$

- Window size N

- Long enough to capture the minimum probability P_{\min}^r

Rate Adaptation for Multicast

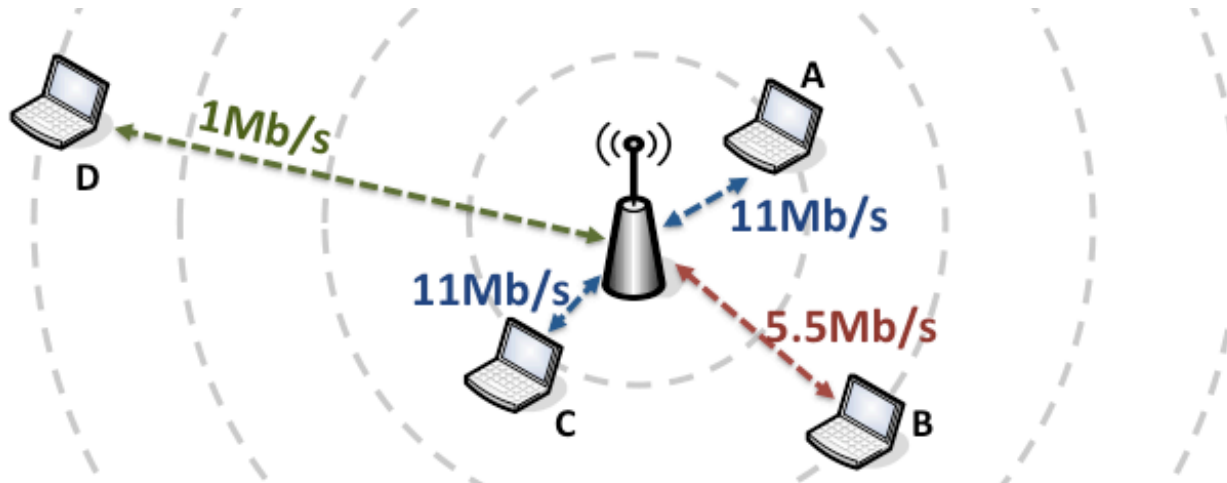

- Why it is difficult?
 - Can only assign a single rate to each packet
 - But the channel conditions of clients are different
- Possible Solutions
 - **For reliable transmission**: select the rate based on the worst node
 - **For non-reliable transmission**: provide clients heterogeneous throughput

Reliable Multicast Protocol

- Before rate adaptation, we should first ask:
 - How to efficiently collect ACK from multicast clients?
- Leader-based Protocol (LBP)
 - Select one of the receivers as the leader to reply ACK
 - **Leader**
 - if receive successfully, **send ACK**
 - otherwise, **send NACK**
 - **Others**
 - if receive successfully, **do nothing**
 - otherwise, **send NACK**
 - **Retransmit if the AP receives any NACK**

J. Kuri and S. Kasera, "Reliable Multicast in Multi-Access Wireless LANs,"
IEEE INFOCOM, Mar. 1999.

Rate Adaptation for Data Multicast

- Rate Adaptive Reliable Multicast (RAM)
 - Should pick the bit-rate based on the channel of the worst receiver
- Say we have three receivers A, B, and C
 - Each receiver feedbacks CTS at its optimal rate chosen based on its SNR
 - The AP detects the lowest rate by measuring the longest channel time occupied by CTS

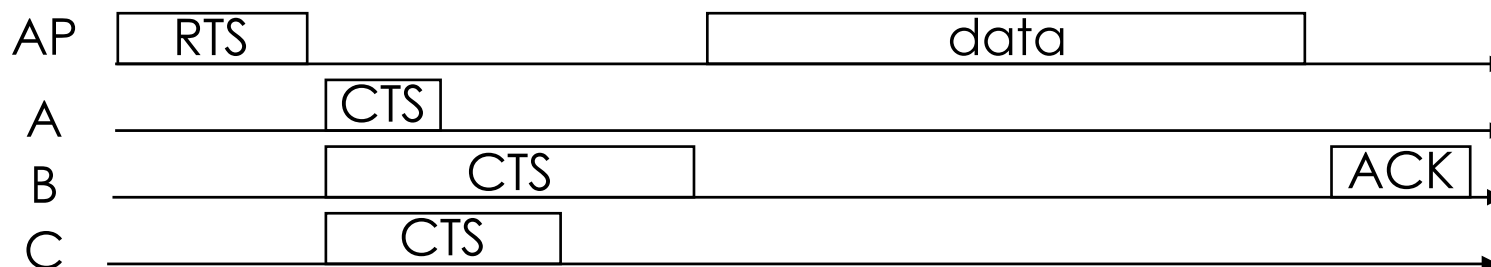

Rate Adaptation for Video Multicast

- Video codec usually allows some losses
 - Receive more frames → better video quality
 - Receive less frame → lower video quality
- No need to receive everything
 - No need to be constrained by the channel of the worst receiver
- One would expect a video quality proportional to its channel condition, i.e., differential QoS
 - Higher SNR → better video quality
 - Lower SNR → lower video quality

J. Villalon et. Al., "Cross-Layer Architecture for Adaptive Video Multicast Streaming over Multirate Wireless LANs," IEEE JSAC, vol. 25, no. 4, pp. 699-711, May 2007.

Rate Adaptation for Video Multicast

- H-ARSM (Hybrid Auto Rate Selection Mechanism)
- Mainly consider two video layers: **base layer** and **enhancement layer**

Heuristic; not really optimizing for QoS/QoE

Design principles

- **Guarantee a minimum video quality**
 - Ensure that everyone reliably gets the base layer
 - Again, send at the rate according to the worst receiver
- **Pick a more aggressive rate for the enhancement layer**
 - Use **the next higher rate** if there exist one (or more) receivers with an SNR above the threshold of that rate

Recent Proposals

- ZipTx

K. Lin, N. Kushman and D. Katabi, “Harnessing Partial Packets in 802.11 Networks,” ACM MOBICOM, 2008

Exploit partial packets with consideration of bit-rate adaptation

- SoftRate

M. Vutukuru, H. Balakrishnan and K. Jamieson, “Cross-Layer Wireless Bit Rate Adaptation,” ACM SIGCOMM, 2009

Exploit soft information to improve selection accuracy

- FARA

H. Rahul, F. Edalat, D. Katabi and C. Sodini, “Frequency-Aware Rate Adaptation and MAC Protocols,” ACM MOBICOM, 2009

Adapt the bit-rate for every OFDM subcarrier

- ESNR

D. Halperin, W. Hu, A. Sheth and D. Wetherall, “Predictable 802.11 Packet Delivery from Wireless Channel Measurements”, ACM SIGCOMM, 2010

Consider frequency selective fading