

# Chapter 2: Wireless IP Network Architectures

Jyh-Cheng Chen and Tao Zhang

IP-Based Next-Generation Wireless Networks  
Published by John Wiley & Sons, Inc.  
January 2004

Copyright © 2004 by John Wiley & Sons, Inc. All rights reserved.

**This material is protected under all  
Copyright Laws as they currently exist.  
©2004 Jyh-Cheng Chen and Tao Zhang,  
and John Wiley & Sons, Inc. All rights  
reserved. Notwithstanding user's ability to  
use and modify the PowerPoint Slides, it is  
understood that the original version of  
these slides, as well as any and all  
modifications thereof, and all  
corresponding copyrights, shall at all times  
remain the property of Jyh-Cheng Chen  
and Tao Zhang, and John Wiley & Sons, Inc.**

Copyright © 2004 by John Wiley & Sons, Inc. All rights reserved.

2

## Outline

- 2.1 3GPP Packet Data Networks
- 2.2 3GPP2 Packet Data Networks
- 2.3 MWIF All-IP Mobile Networks

## 2.1 3GPP Packet Data Networks

- ◆ 2.1.1 Network Architecture
- ◆ 2.1.2 Protocol Reference Model
- ◆ 2.1.3 Packet Data Protocols, Bearers, and Connections for Packet Services
- ◆ 2.1.4 Packet Data Protocol (PDP) Context
- ◆ 2.1.5 Steps for a Mobile to Access 3GPP Packet-Switched Services
- ◆ 2.1.6 User Packet Routing and Transport
- ◆ 2.1.7 Configuring PDP Addresses on Mobile Stations
- ◆ 2.1.8 GPRS Attach Procedure
- ◆ 2.1.9 PDP Context Activation and Modification
- ◆ 2.1.10 Radio Access Bearer Assignment
- ◆ 2.1.11 Packet-Switched Domain Protocol Stacks
- ◆ 2.1.12 Accessing IP Networks through PS Domain

## 2.1.1 Network Architecture

- ◆ Public Land Mobile Network (PLMN): a public network administrated by a single network operator for providing land mobile services
- ◆ Radio Access Networks (RANs)
  - GSM/EDGE RAN (GERAN)
  - UMTS Terrestrial RAN (UTRAN)
  - Broadband Radio Access Networks (BRANs)
- ◆ Core Network (CN)
  - Circuit-Switched (CS) Domain
  - Packet-Switched (PS) Domain
  - IP Multimedia Subsystem (IMS)
  - Information Servers

Fig. 2.1 3GPP conceptual network architecture (Release 5)

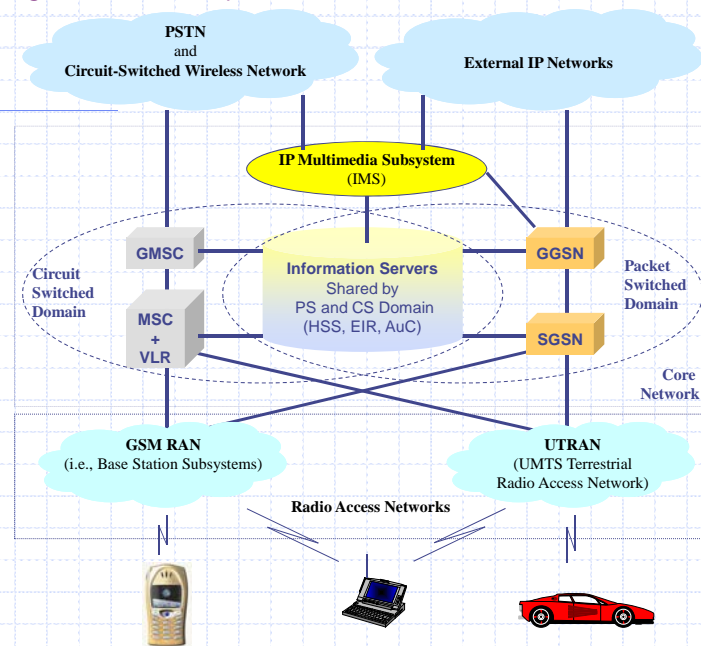

## GERAN and UTRAN

### ◆ GERAN

- Base Station Subsystem (BSS)
  - ◆ Base Transceiver Station (BTS)
  - ◆ Base Station Controller (BSC)

### ◆ UTRAN

- Radio Network Subsystem (RNS)
  - ◆ Node B
  - ◆ Radio Network Controller (RNC)

## 2.1.1.1 Mobile Devices, Subscribers, and Their Identifiers

### ◆ Mobile Station (MS): in GSM

### ◆ User Equipment (UE): in UMTS

- Mobile Equipment (ME)
  - ◆ Terminal Equipment (TE)
  - ◆ Mobile Termination (MT)
    - Terminal Adapter (TA)
- UMTS Subscriber Identity Module (USIM)

**Fig. 2.2** Functional architecture of an user equipment (UE)

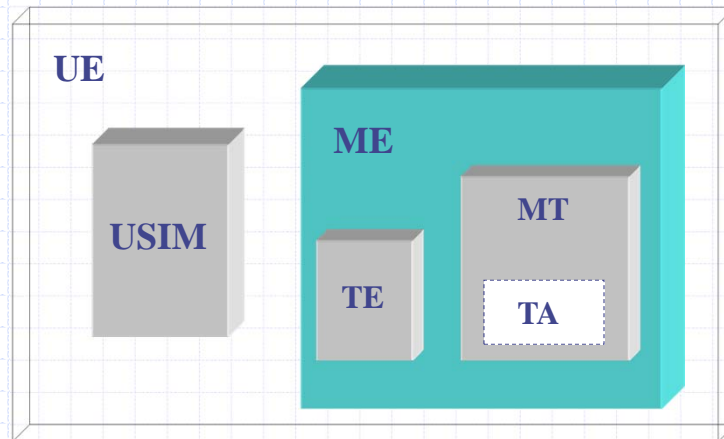

Copyright © 2004 by John Wiley & Sons, Inc. All rights reserved.

9

## Identifiers

- ◆ International Mobile Station Equipment Identity (IMEI): identify MT
  - manufacturer, country, type
- ◆ International Mobile Subscriber Identity (IMSI): globally unique and permanently assigned for each subscriber
  - stored on USIM

Copyright © 2004 by John Wiley & Sons, Inc. All rights reserved.

10

## Fig. 2.3 Structure of International Mobile Subscriber Identity (IMSI)

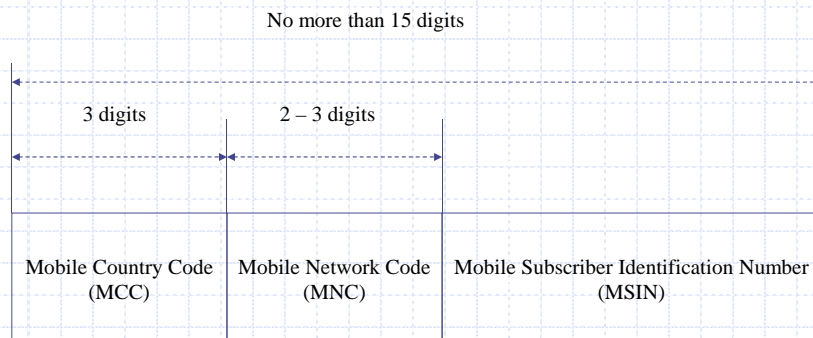

Copyright © 2004 by John Wiley & Sons, Inc. All rights reserved.

11

## Identifiers (Cont.)

- ◆ Temporary Mobile Subscriber Identity (TMSI)
  - 4-octet number assigned to a mobile temporarily by a MSC/VLR or by a SGSN
  - P-TMSI
  - mapping between TMSI and IMSI: only known by mobile and network
- ◆ IP address
  - single or multiple
  - may acquire an IP address only when necessary

Copyright © 2004 by John Wiley & Sons, Inc. All rights reserved.

12

## 2.1.1.2 Circuit-Switched Domain in Core Network

- ◆ Mobile-services Switching Center (MSC)
- ◆ Gateway MSC (GMSC)
- ◆ Visitor Location Register (VLR)
- ◆ Home Subscriber Server (HSS), Equipment Identity Register (EIR), and Authentication Center (AuC)

## Switching vs. Call Control

- ◆ MSC Server: call control and mobility management
- ◆ CS Media Gateway (CS-MGW): circuit switching, media conversion, payload processing (e.g., echo canceller, codec), payload transport

### 2.1.1.3 Packet-Switched Domain in the Core Network

- ◆ Network access control: registration, authentication and authorization, admission control, message filtering, usage data collection
- ◆ Packet routing and transport: route user packets toward their destinations
- ◆ Mobility management: tracking the locations of mobile terminals, initiating paging, maintaining up-to-date routes

### Serving GPRS Support Node (SGSN)

- ◆ Access control
- ◆ Location management: track the locations of mobiles; may report the location information to the HLR
- ◆ Route management: maintain and relay user traffic between the mobile and the GGSN
- ◆ Paging: initiating paging to idle mobiles
- ◆ Interface with service control platforms: contact point with CAMEL (Customized Applications for Mobile Enhanced Logic)



## Gateway GPRS Support Node (GGSN)

- ◆ Packet routing and forwarding center: all user packets to and from a mobile in a PLMN will be sent first to a GGSN (refer to as the mobile's serving GGSN)
- ◆ Route and mobility management: maintain a route to the SGSN that is currently serving a mobile and uses the route to exchange the user traffic with the SGSN

## Identifiers of SGSN and GGSN

- ◆ IP address
  - may be private IP address
- ◆ SGSN Number and GGSN Number
  - used primarily with non-IP protocols, e.g., MAP or other SS7-based protocols

## 2.1.1.4 IP Multimedia Subsystem

- ◆ Release 5 introduced the IP Multimedia Subsystem (IMS)
- ◆ Support real-time voice and multimedia IP services
- ◆ Use the Session Initiation Protocol (SIP) for signaling and session control for all real-time multimedia services
- ◆ Will be discussed in Chapter 3

## 2.1.1.5 Information Servers

- ◆ Shared by CS and PS domains
- ◆ Home Subscriber Server (HSS)
  - master logical database
  - maintain user subscription information to control network services
  - Home Location Registrar (HLR): main component of HSS which maintains users' identities, locations, and service subscription information
- ◆ Authentication Center (AuC)
  - maintain information to authenticate each user and to encrypt the communication
  - accessed by the HSS
- ◆ Equipment Identity Register (EIR)
  - maintain IMEIs of the subscribers

## 2.1.2 Protocol Reference Model

- ◆ RAN Internal Interfaces
- ◆ RAN-to-CN Interfaces
- ◆ CS CN Internal Interfaces
  - many interfaces use MAP protocol
- ◆ PS CN Internal Interfaces

Fig. 2.4

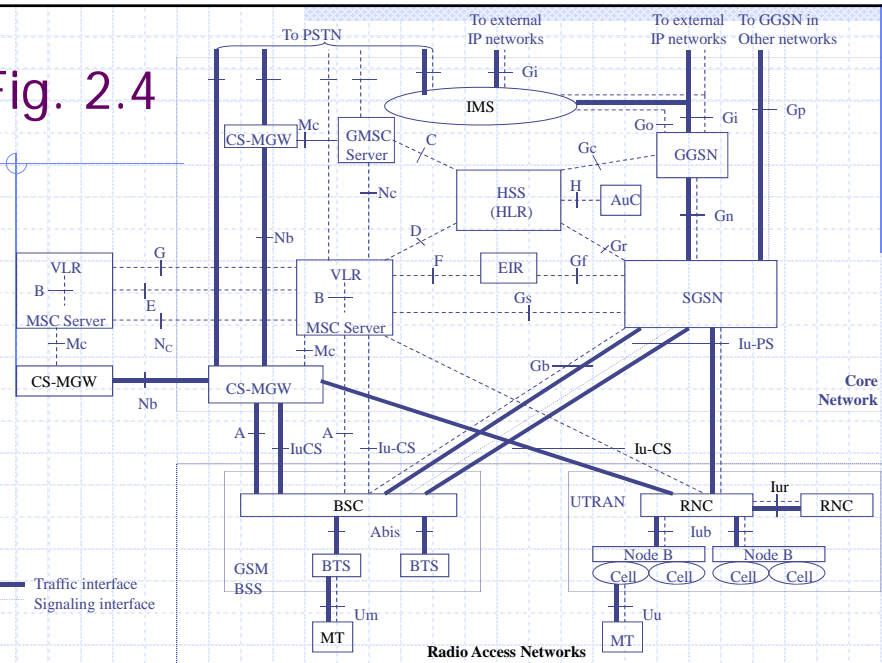

## RAN Internal Interfaces

### ◆ GERAN

- A<sub>bis</sub>
- U<sub>m</sub>

### ◆ UTRAN

- I<sub>ub</sub>
- I<sub>ur</sub>: logical signaling interface
- U<sub>u</sub>

## RAN-to-CN Interfaces

### ◆ GERAN

- A or I<sub>u</sub>-CS: CS CN domain
- G<sub>b</sub> or I<sub>u</sub>-PS: PS CN domain

### ◆ UTRAN

- I<sub>u</sub>-CS: CS CN domain
- I<sub>u</sub>-PS: PS CN domain

### ◆ One and only one mode

- A/G<sub>b</sub> mode
- I<sub>u</sub> mode

**Fig. 2.5 Protocol reference model for 3GPP PS domain**

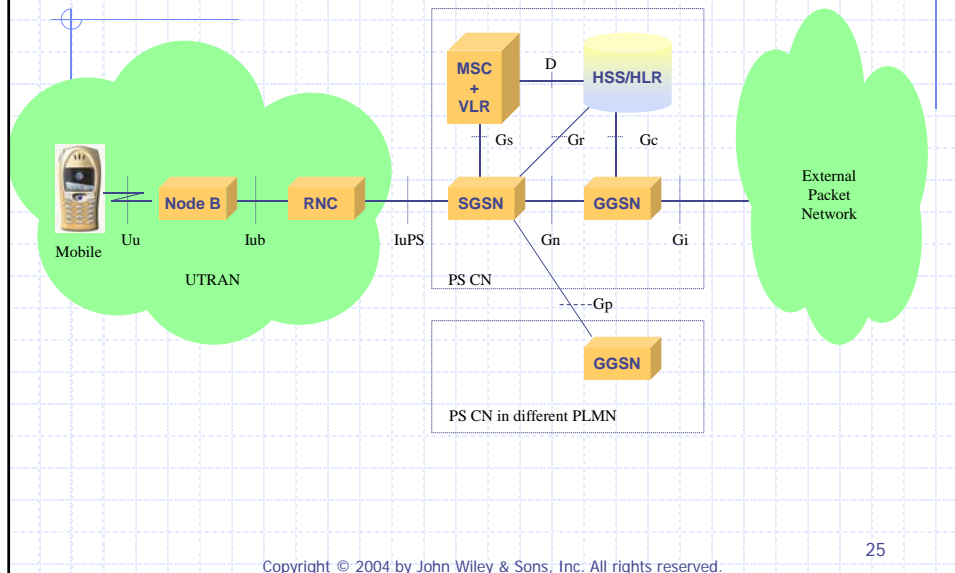

### 2.1.3 Packet Data Protocols, Bearers, and Connections for Packet Services

- ◆ Packet Data Protocol (PDP): used to exchange user packets over a 3GPP PS CN domain
- ◆ Packet Data Unit (PDU): user packet transported inside a 3GPP network over traffic bearer
- ◆ Traffic bearer: a set of network resources and data transport functions used to deliver user traffic between two network entities

**Fig. 2.6** 3GPP bearers (connections) for supporting packet-switched services

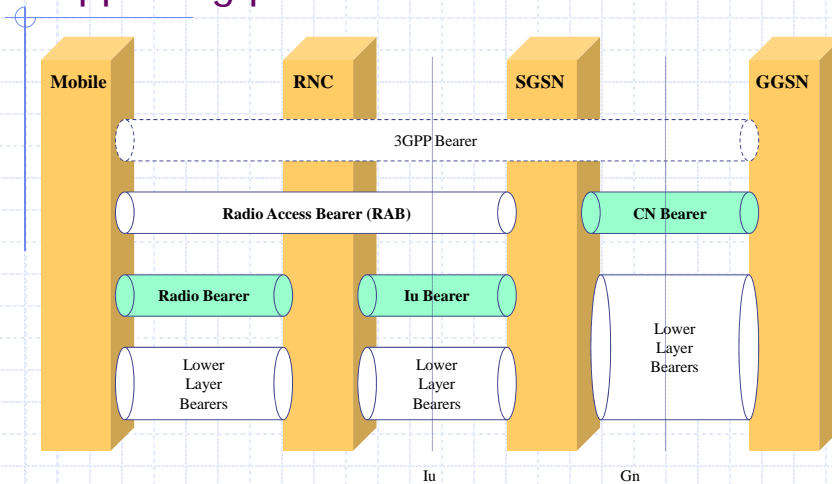

Copyright © 2004 by John Wiley & Sons, Inc. All rights reserved.

27

## Separation of Bearers

- ◆ The (Traffic) Radio Bearers,  $I_u$  (Traffic) Bearers, Radio Access Bearers, and CN Bearers are managed by different protocols and procedures.
  - allows different protocols and procedures to be used; evolve with less dependency on each other
  - facilitates mobility management

Copyright © 2004 by John Wiley & Sons, Inc. All rights reserved.

28

**Fig. 2.7** Signaling and traffic connections between mobile and SGSN

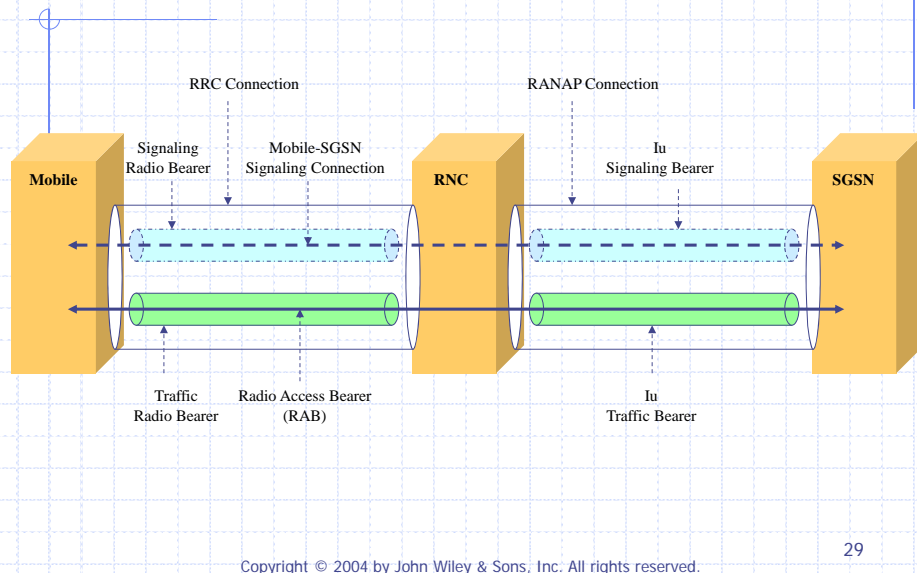

## Connections

- ◆ Radio Resource Control (RRC) connection
  - Signaling Radio Bearer
  - Traffic Radio Bearer
- ◆ Radio Access Network Application Part (RANAP) connection
  - I<sub>u</sub> Signaling Bearers
  - I<sub>u</sub> Traffic Bearers

## 2.1.4 Packet Data Protocol (PDP) Context

- ◆ A set of information that the network uses to determine how to forward user packets destined to and originated from a particular PDP address
- ◆ Contain the following main information
  - PDP Address
  - Routing Information: identifiers of tunnels and Access Point Name (APN)
  - Quality of Service (QoS) Profiles: QoS Profile Subscribed, QoS Profile Requested, QoS Profile Negotiated

## PDP States

- ◆ ACTIVE state
  - contains update-to-date information for forwarding PDP packets between the mobile and the GGSN
  - RABs may be established only when there are user packets
- ◆ INACTIVE state
  - may contain a valid PDP address, but will not contain valid routing and mapping information needed to determine how to process PDP packets
  - no user data can be transferred
  - changing location of a mobile user will not cause an update for the PDP context
  - If a GGSN has user packets to send to a mobile, the GGSN may use Network-requested PDP Context Activation procedure to change the PDP context of the destination mobile into ACTIVE state.
  - The GGSN may also discard packets destined to a mobile if the corresponding PDP context is in INACTIVE state.



## Fig. 2.8 3GPP PDP context state transitions

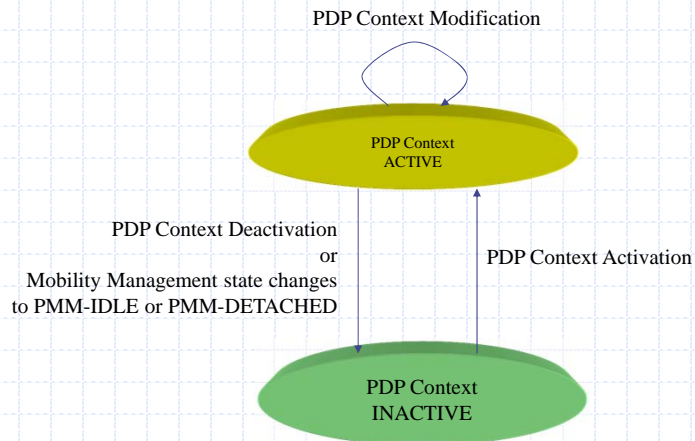

Copyright © 2004 by John Wiley & Sons, Inc. All rights reserved.

33

## State Transition

- ◆ PDP Context Activation
- ◆ PDP Context Modification
  - modify the PDP Address or the attributes of the QoS profile
  - Release 5 only allows the GGSN-initiated PDP Context Modification
- ◆ PDP Context Deactivation

Copyright © 2004 by John Wiley & Sons, Inc. All rights reserved.

34

## 2.1.5 Steps for a Mobile to Access 3GPP Packet-Switched Services

- ◆ GPRS Attach
- ◆ PDP Context Activation and RAB Establishment
- ◆ Register with the IMS

Copyright © 2004 by John Wiley & Sons, Inc. All rights reserved.

35

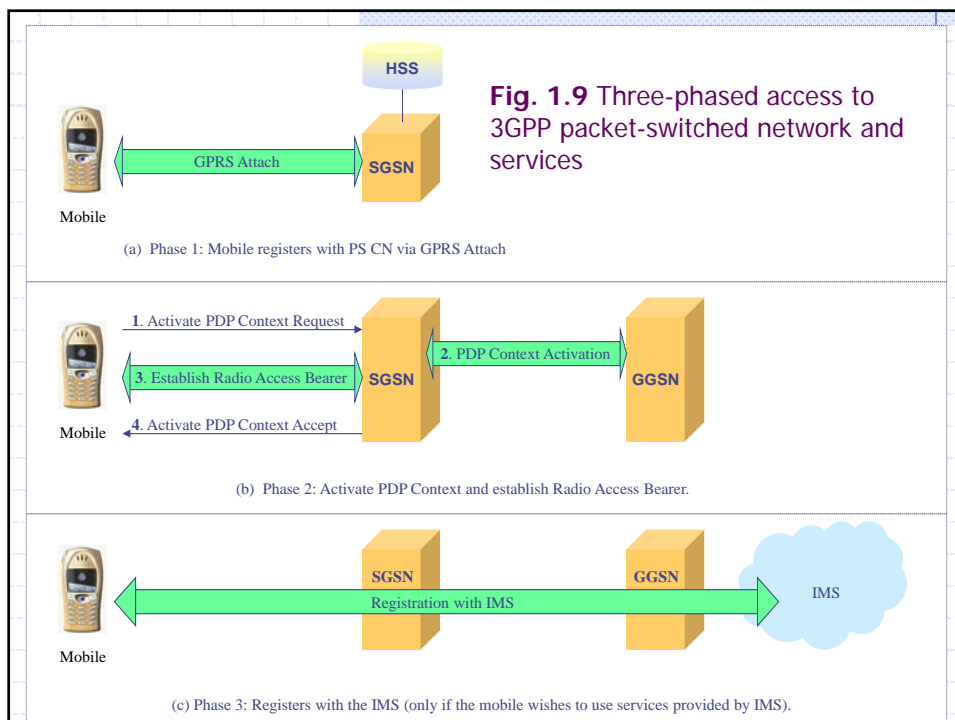

## GPRS Attach

- ◆ A mobile registers with SGSN.
- ◆ A mobile provides its identity and service requirements to the SGSN and will be authenticated and authorized by the SGSN.
- ◆ Establish a Mobility Management Context on the mobile, in the RAN, and on the SGSN. This allows the RAN and the SGSN to track the mobile's location.
- ◆ Establish a signaling connection between the mobile and the SGSN. The mobile and the SGSN use this signaling connection to exchange signaling and control messages needed to perform the GPRS Attach procedure.
- ◆ Allow the mobile to access some services provided by the SGSN. Such services include sending and receiving SMS messages and being paged by the SGSN.

## PDP Context Activation and RAB Establishment

- ◆ A mobile can request the network to establish and activate a PDP Context for its PDP address after the mobile has performed GPRS Attach successfully.
- ◆ A successful PDP context activation will trigger the PS CN domain to establish the CN Bearer and the RAB.
- ◆ A mobile will be able to send and receive user packets over the PS CN domain.

## Register with the IMS

- ◆ When a mobile wishes to use the IP-based real-time voice or multimedia services provided by the IMS, the mobile needs to perform registration with the IMS.
- ◆ SIP registration procedure is used for a user to register with the IMS.
- ◆ Will be described in detail in Chapter 3

## 2.1.6 User Packet Routing and Transport

- ◆ Inside the PS CN domain, IP is the main protocol for transporting user packets between network nodes.
- ◆ IP is used for routing between GGSNs.
- ◆ Routing of user packets between SGSN and GGSN is based on GPRS-specific protocols and procedures.

# Packet Routing

- ◆ GGSN acts as a central point for routing of all user packets.
- ◆ User packets are tunneled between RNC and SGSN, between SGSN and GGSN, and between two SGSNs.
  - GPRS Tunneling Protocol (GTP): routing and mobility management
- ◆ Host-specific routes are used to forward user packets between a mobile and a GGSN.
  - maintain an individual routing entry as part of a PDP context for every mobile terminal that has an active PDP context

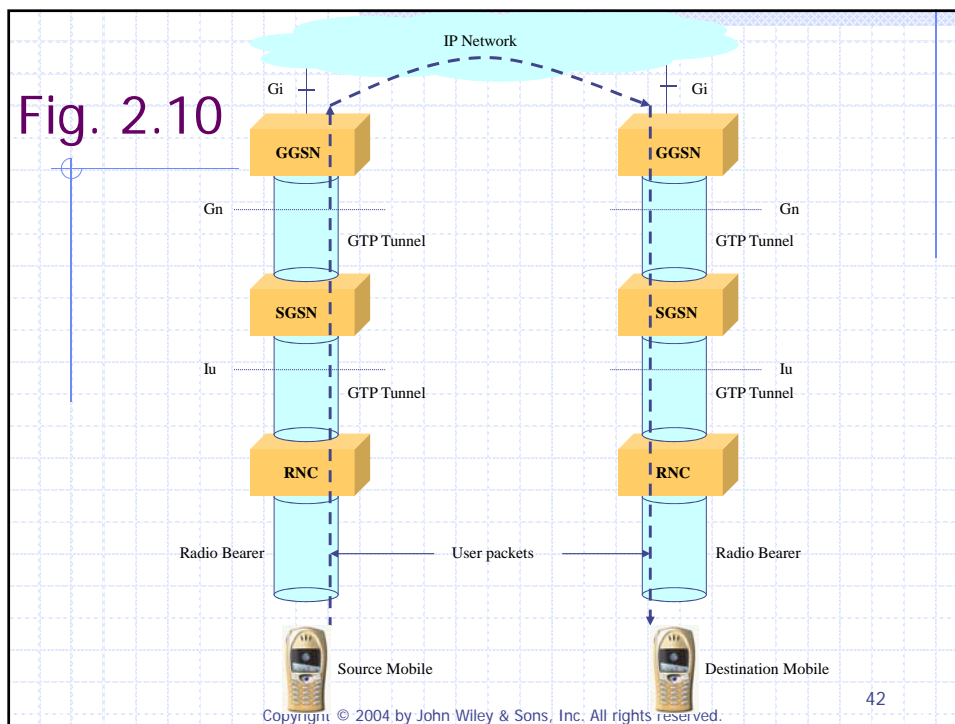

## Mapping between Identifiers

- ◆ Packets addressed to the PDP address are delivered by the lower protocol to the IP layer through the Service Access Point.
  - identified by a Network-layer Service Access Point Identifier (NSAPI)
  - a unique NAPI is used for each IP address
- ◆ Tunnel Endpoint Identifier (TEID)
  - exchanged during tunnel setup process
- ◆ Radio Access Bearer Identifier (RAB ID)
- ◆ Radio Bearer Identifier (RB ID)

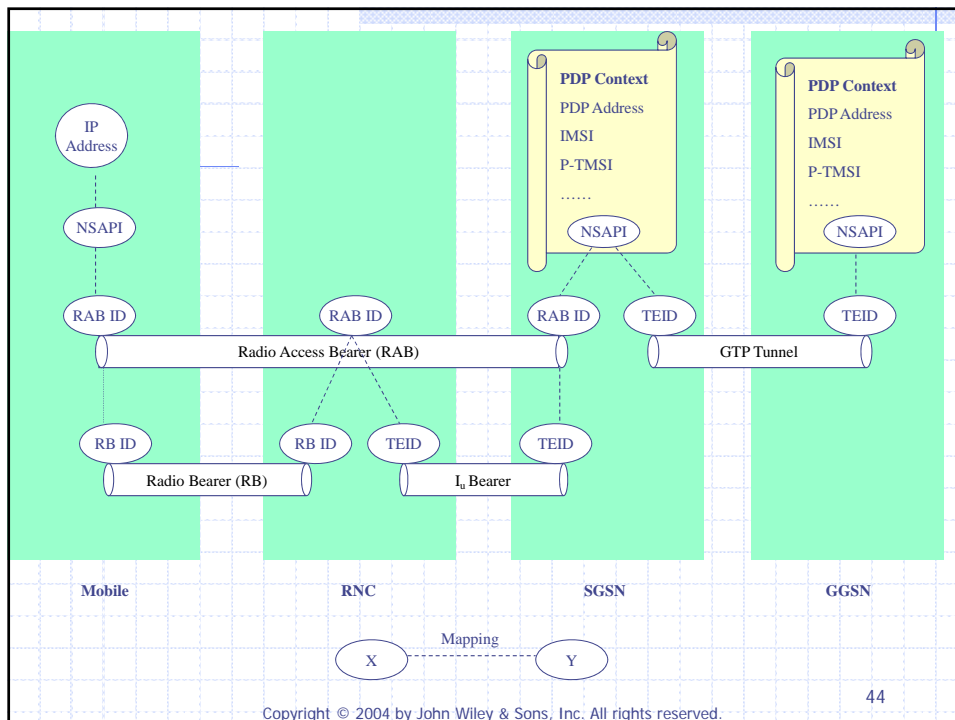

## 2.1.7 Configuring PDP Addresses on Mobile Stations

- ◆ Use a static PDP address assigned by the visited 3GPP network
- ◆ Use a static PDP address assigned by an external IP network
- ◆ Acquire a PDP address dynamically from the visited 3GPP network
- ◆ Acquire a PDP address dynamically from an external IP network

## Dynamic PDP Address from an External IP Network

- ◆ The visited PS domain first activates a PDP context without a PDP address for the mobile.
- ◆ The visited PS CN will not forward other user packets to or from the mobile before a valid PDP address is added to the mobile's PDP context.
- ◆ The mobile's serving GGSN in the visited network will have to learn the PDP address assigned to the mobile.

## 2.1.8 GPRS Attach Procedure

- ◆ GPRS Attach procedure to attach to the PS domain
- ◆ IMSI Attach procedure to attach to the CS domain
- ◆ May combine GPRS Attach procedure and IMSI Attach procedure to attach to the PS and the CS domain simultaneously

Copyright © 2004 by John Wiley & Sons, Inc. All rights reserved.

47

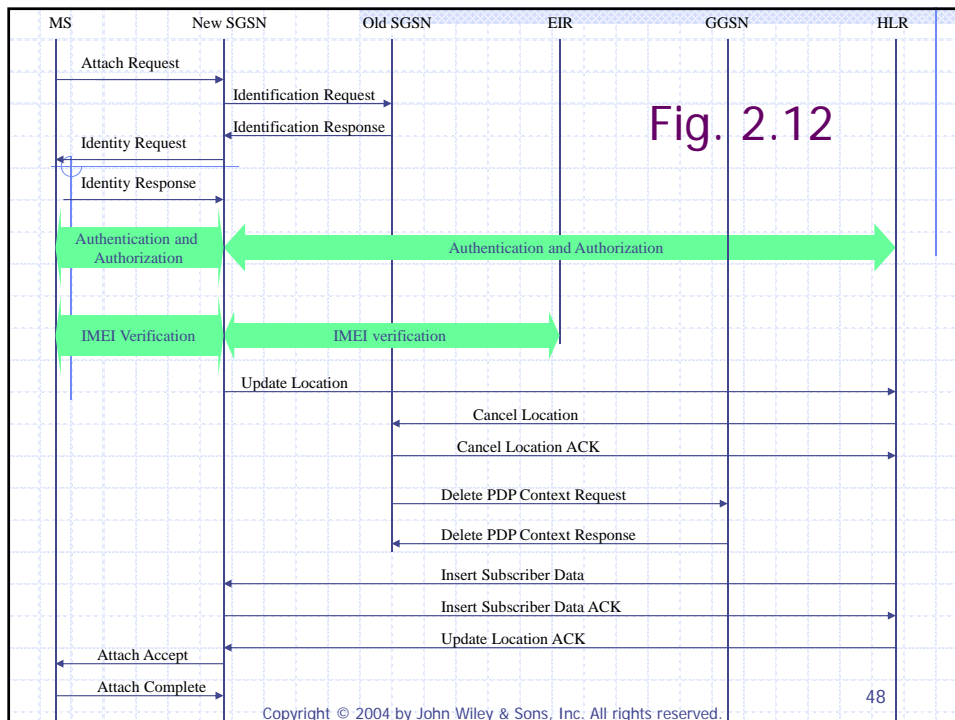

48



## Attach Request

- ◆ Identifiers of the mobile: P-TMSI or its IMSI, but not both
- ◆ P-TMSI Signature:
  - 3-octet number assigned to the mobile by the SGSN that assigned the P-TMSI
  - used by the SGSNs to authenticate a P-TMSI
  - can also be used by the mobile to authenticate the network node that is assigning the P-TMSI
- ◆ Attach Type: indicate whether the Attach Request is for GPRS Attach only, GPRS Attach while already IMSI attached, or combined GPRS/IMSI Attach
- ◆ Location information: Routing Area Identity (RAI) (will be discussed in more detail in Chapter 4)

## 2.1.9 PDP Context Activation and Modification

- ◆ PDP Address allocation: The network allocates an PDP address to the mobile if needed.
- ◆ CN Bearer Establishment: The network creates and activates the PDP context on GGSN and SGSN and establishes all the necessary bearers between SGSN and GGSN for transporting user and signaling traffic for the activated PDP context.
- ◆ RAB Assignment: The network establishes the Radio Access Bearers to carry user traffic.

## 2.1.9 PDP Context Activation and Modification (Cont.)

- ◆ 2.1.9.1 Mobile-Initiated PDP Context Activation and Modification
- ◆ 2.1.9.2 Network-Requested PDP Context Activation
- ◆ 2.1.9.3 PDP Context Modification

### 2.1.9.1 Mobile-Initiated PDP Context Activation and Modification

- ◆ Activate PDP Context Request
  - PDP Address: either 0.0.0.0 or specified by the mobile
  - Network-layer Service Access Point Identifier (NSAPI)
  - PDP Type
  - Access Point Name (APN)
  - QoS Requested
  - PDP Configuration Options: optional PDP parameters directly with GGSN

## Fig. 2.13 3GPP mobile-initiated PDP context activation

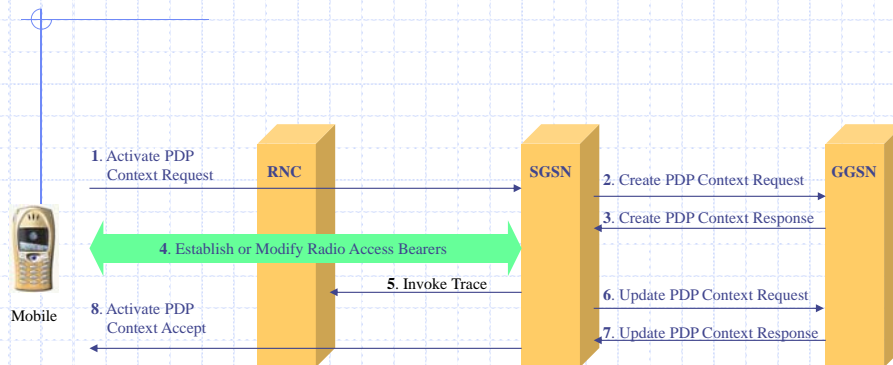

Copyright © 2004 by John Wiley & Sons, Inc. All rights reserved.

53

## Access Point Name (APN)

- ◆ Select a service (or a GGSN) in the PS domain or a contact point in an external packet network
- ◆ Contain two main parts
  - APN Network Identifier
  - APN Operator Identifier: identify the PLMN (optional)
- ◆ Same name syntax as the Internet Domain Name
- ◆ Domain Name System (DNS) can be used to translate an APN to an IP address

Copyright © 2004 by John Wiley & Sons, Inc. All rights reserved.

54

## Create PDP Context Request

- ◆ NSAPI: copied from Activate PDP Context Request
- ◆ PDP Type: copied from Activate PDP Context Request
- ◆ PDP Address: from the Activate PDP Context Request message
- ◆ APN: selected by SGSN
- ◆ QoS negotiated: QoS profile the SGSN agrees to support
- ◆ Tunnel Endpoint Identifier (TEID): created by SGSN based on mobile's IMSI and on the NSAPI in the Activate PDP Context Request
- ◆ Selection Mode: whether the APN was subscribed by mobile or selected by SGSN
- ◆ Charging Characteristics: what kind of charging the PDP context is liable for
- ◆ PDP Configuration Options: copied from the Activate PDP Context Request

## Create PDP Context Response

- ◆ TEID: to identify the GGSN side of the GTP tunnel
- ◆ PDP Address:
  - a PDP address assigned by the GGSN
  - 0.0.0.0 if the mobile asks to acquire from an external network
- ◆ QoS Negotiated: QoS profile agreed by the GGSN
- ◆ PDP Configuration Options: relayed by intermediate nodes transparently to the mobile

## 2.1.9.2 Network-Requested PDP Context Activation

- ◆ GGSN must have *static* information about the PDP address
  - For example, the GGSN needs to know the mobile's IMSI in order to query the HLR
- ◆ A Request PDP Context Activation message to the mobile to instruct the mobile to start the Mobile-initiated PDP Context Activation procedure described in Figure 2.13

Copyright © 2004 by John Wiley & Sons, Inc. All rights reserved.

57

## Fig. 2.14 3GPP network-requested PDP context activation

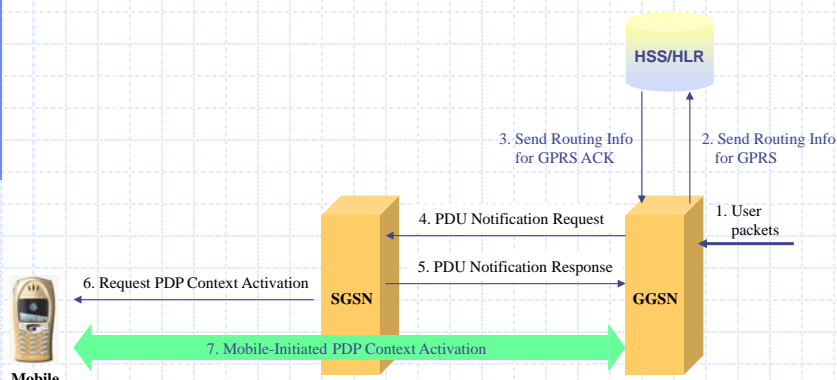

Copyright © 2004 by John Wiley & Sons, Inc. All rights reserved.

58

### 2.1.9.3 PDP Context Modification

- ◆ Active PDP context can be modified
- ◆ PDP address: only a GGSN can initiate the process to modify the PDP address in an active PDP context
- ◆ QoS profiles: can be initiated by the mobile, GGSN, SGSN, or the RAN

### Fig. 2.15 3GPP GGSN-initiated PDP context modification

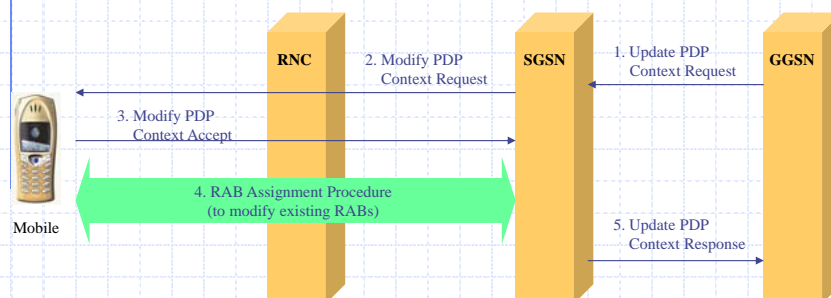

## Update PDP Context Request

- ◆ TEID: identify the SGSN end of the GTP tunnel
- ◆ NSAPI: identify the PDP context to be modified
- ◆ PDP Address: a new PDP address if the GGSN wishes to modify the PDP Address (optional)
- ◆ QoS Requested: new QoS profile suggested by the GGSN

## 2.1.10 Radio Access Bearer Assignment

- ◆ RAB Assignment: assignment, modification and release of RAB
- ◆ In R5, can only be initiated by the network
  - initiated by the SGSN upon triggered by other network entities in the CN or the RAN
- ◆ Radio Resource Control (RRC) protocol will be used to establish, maintain, and release the Radio Bearers
- ◆ SGSN negotiates with the RAN about the QoS profile for the mobile

## Fig. 1.16 3GPP Radio Access Bearer Assignment

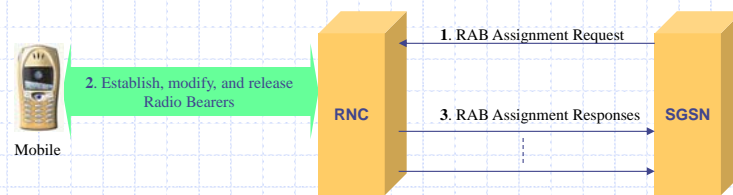

Copyright © 2004 by John Wiley & Sons, Inc. All rights reserved.

63

## 2.1.11 Packet-Switched Domain Protocol Stacks

- ◆ 2.1.11.1 Gn and Gp interfaces and the GPRS Tunneling Protocol
- ◆ 2.1.11.2 The Iu-PS Interface
- ◆ 2.1.11.3 Gi, Gr, Gc, and Gs Interfaces
- ◆ 2.1.11.4 Mobile-to-GGSN Protocol Stacks

Copyright © 2004 by John Wiley & Sons, Inc. All rights reserved.

64



## 2.1.11.1 Gn and Gp interfaces and the GPRS Tunneling Protocol

- ◆ Gn: between SGSN and GGSN as well as SGSNs in the same PLMN
- ◆ Gp: between an SGSN and a GGSN in a different PLMN
- ◆ GPRS Tunneling Protocol (GTP) is used for both user plane and control plane

## Fig. 1.17 3GPP Gn and Gp interface protocol stacks

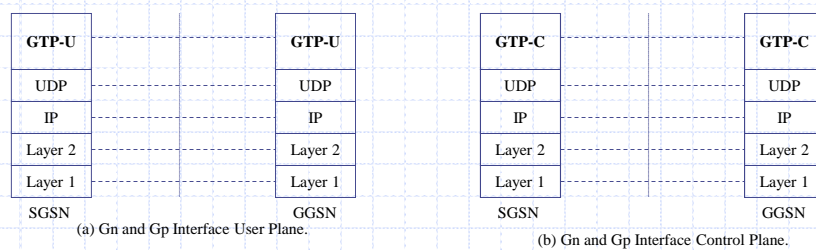

## GPRS Tunneling Protocol (GTP)

- ◆ GTP-C: manage (create, modify, and release) GTP-U tunnels, manage PDP contexts, location management, and mobility management
  - multiple PDP contexts with the same PDP address will share a common GTP-C tunnel
- ◆ GTP-U: establish and manage GTP tunnels used to tunnel user packets
  - one GTP-U tunnel between SGSN and GGSN will be established for every active PDP context

## GTP Messages

- ◆ Tunnel Management: activate, modify and remove PDP Contexts and their associated GTP tunnels
- ◆ Location Management: used by a GGSN to retrieve location information from the HLR
- ◆ Mobility Management: used between SGSNs to transfer mobility related information
- ◆ Path Management: used by a node to determine if a peer node is alive and to inform the peer node of what GTP header extensions it can support

# GTP Header Format

- ◆ Version: 1 for the current version
- ◆ PT (Protocol Type): for 3GPP CN or GPRS/GSM
- ◆ E (Extension header Flag): indicates whether the Next Extension Header is present
- ◆ S (Sequence Number flag): indicates if the Sequence Number field is present
- ◆ PN (N-PDU Number Flag): indicates whether the N-PDU Number field is present
- ◆ Message Type: indicates the type of the GTP message
- ◆ N-PDU Number: used in inter-SGSN Routing Area Update procedure and some inter-system handoff procedures for coordinating data transmission between a mobile terminal and a SGSN

# Fig. 2.18 GPRS Tunneling Protocol (GTP) header format

8	7	6	5	4	3	2	1
Version		PT	(*)	E	S	PN	
Message Type							
Length (1 <sup>st</sup> octet)							
Length (2 <sup>nd</sup> octet)							
Tunnel Endpoint Identifier (1 <sup>st</sup> octet)							
Tunnel Endpoint Identifier (2 <sup>nd</sup> octet)							
Tunnel Endpoint Identifier (3 <sup>rd</sup> octet)							
Tunnel Endpoint Identifier (4 <sup>th</sup> octet)							
Sequence Number (optional) (1 <sup>st</sup> octet)							
Sequence Number (optional) (2 <sup>nd</sup> octet)							
N-PDU Number (optional)							
Next Extension Header Type (optional)							

## 2.1.11.2 The Iu-PS Interface

- ◆ Tunnel Management: establishing, maintaining and releasing the GTP tunnels between a RNC and a SGSN
- ◆ Radio Access Bearer Management: establishing, maintaining and releasing Radio Access Bearers (RABs)
- ◆ Radio Resource Management: Radio Resource Admission Control by RNC
- ◆ Mobility Management: handoff between RNC; paging; positioning services

## Fig. 2.19 3GPP Iu-PS interface protocol stacks

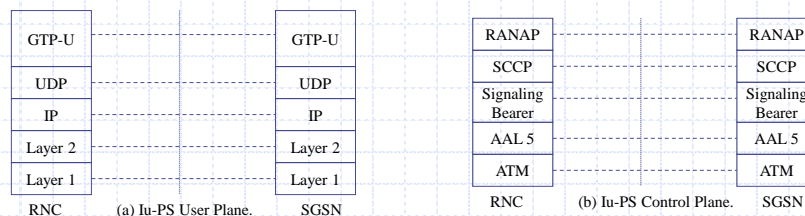

RANAP: Radio Access Network Application Part  
 SCCP: Signaling Connection Control Part

## 2.1.11.3 Gi, Gr, Gc, and Gs Interfaces

- ◆ Gi: used by GGSN to connect to any external IP network
- ◆ Gr: between SGSN and HLR
- ◆ Gc: between GGSN and HLR
- ◆ Gs: between SGSN and MSC/VLR

## Fig. 2.20 3GPP Gi interface protocol stack

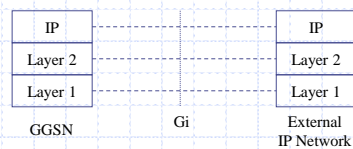

**Fig. 2.21** 3GPP control-plane protocol stack between SGSN (or GGSN) and HLR

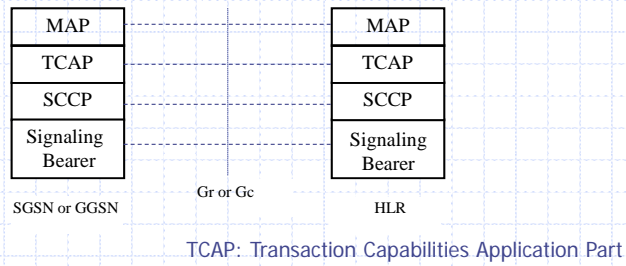

**Fig. 2.22** 3GPP control-plane protocol stack between GGSN and HLR based on GTP

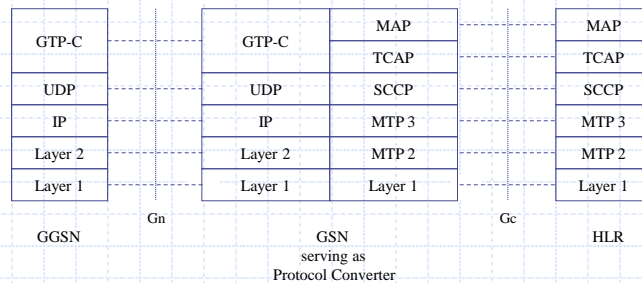

**Fig. 2.23** 3GPP control-plane protocol stack between SGSN and MSC/VLR

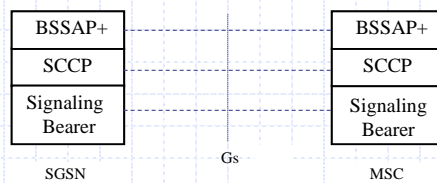

BSSAP+: Base Station System Application Part+

## 2.1.11.4 Mobile-to-GGSN Protocol Stacks

- ◆ Packet Data Convergence Protocol (PDCP)
  - Header compression for higher-layer data streams
    - ◆ IP Header Compression (IPHC)
    - ◆ Robust Header Compression (ROHC)
  - Mapping higher-layer data into the underlying radio interface protocols
  - Maintaining data transmission orders for upper layer protocols that have such requirement

**Fig. 2.24** 3GPP user-plane protocol stack between mobile and GGSN

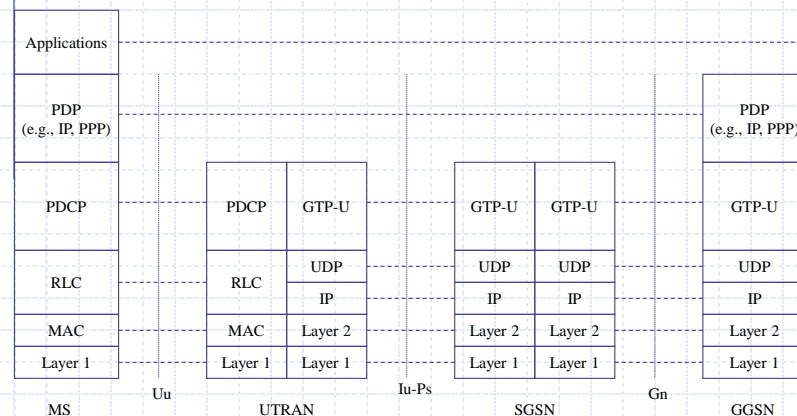

Copyright © 2004 by John Wiley & Sons, Inc. All rights reserved.

79

## Radio Link Control (RLC)

- ◆ Provides logical link control over the radio interfaces
- ◆ A mobile can have multiple RLC connections
- ◆ Support
  - Broadcast information related to the RAN and the CN to the mobiles
  - Establish, maintain, and release RRC connections
  - Establish, maintain, and release Radio Bearers
  - Paging
  - Radio power control
  - Control of radio measurement and reporting
  - Control of the on and off of ciphering between the mobile and the RAN

Copyright © 2004 by John Wiley & Sons, Inc. All rights reserved.

80



**Fig. 2.25** 3GPP control-plane protocol stack between mobile and SGSN

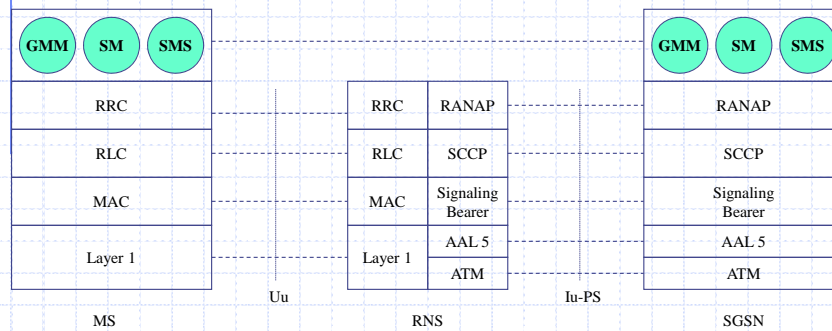

Copyright © 2004 by John Wiley & Sons, Inc. All rights reserved.

81

## GMM, SM, and SMS

- ◆ GPRS Mobility Management (GMM): support mobility management functions including GPRS Attach and Detach operations, security, and routing area update procedure.
- ◆ Session Management (SM): support PDP context activation, modification, and deactivation
- ◆ SMS (Short Message Service): support short messages

Copyright © 2004 by John Wiley & Sons, Inc. All rights reserved.

82

## 2.1.12 Accessing IP Networks through PS Domain

- ◆ User registration (e.g., authentication and authorization) with the external IP network
- ◆ Dynamic assignment of IP addresses to the mobile by the external IP network
- ◆ Encryption of user data transported between the mobile and the external IP network

## Fig. 2.26 Access another IP network through 3GPP PS domain

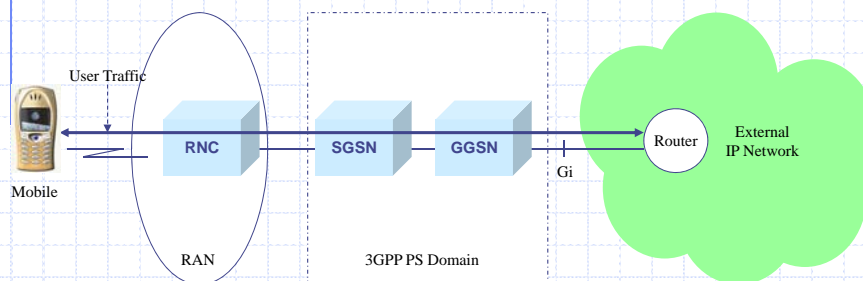

## Transparent Access vs. Non-transparent Access

- ◆ Transparent Access: The GGSN does not participate in any interaction between the mobile and the external IP network except transporting user packets.
- ◆ Non-transparent Access: The GGSN participates in at least one of the interactions between the mobile and the external IP network described above.

## 2.1.12 Accessing IP Networks through PS Domain

- ◆ 2.1.12.1 Transparent Access
- ◆ 2.1.12.2 Non-Transparent Access Using Mobile IP
- ◆ 2.1.12.3 Acquiring IP Address Dynamically Using DHCP from an External Network
- ◆ 2.1.12.4 Dial-up Access Using PPP

## 2.1.12.1 Transparent Access

- ◆ Gain access to a GGSN in the local PS CN
- ◆ Acquire an IP address from the local PS domain to use as its PDP address in local PS CN domain
- ◆ Register with the external IP network

**Fig. 2.27** Protocol stacks for transparent to IP networks through 3GPP PS CN

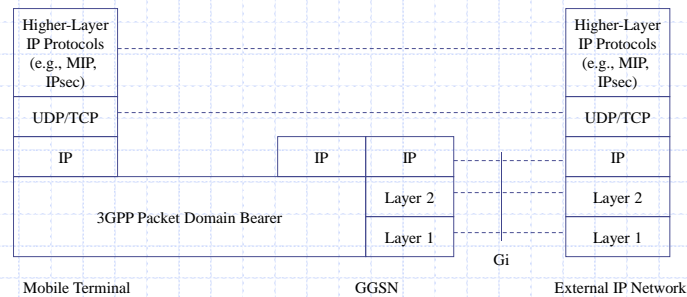

## 2.1.12.2 Non-Transparent Access Using Mobile IP

- ◆ GGSN also serves as a MIPv4 FA
- ◆ Mobile uses the IP address of the GGSN as its FA CoA
- ◆ HA may be inside an external IP network

**Fig. 2.28** Protocol stacks for non-transparent access to IP networks through PS CN domain

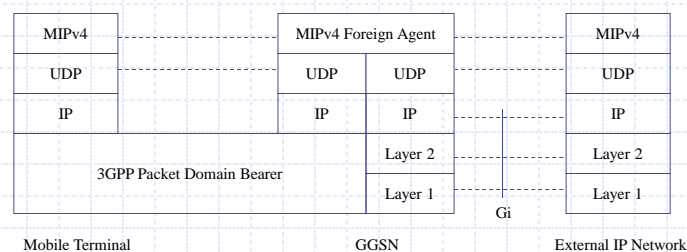

**Fig. 2.29**

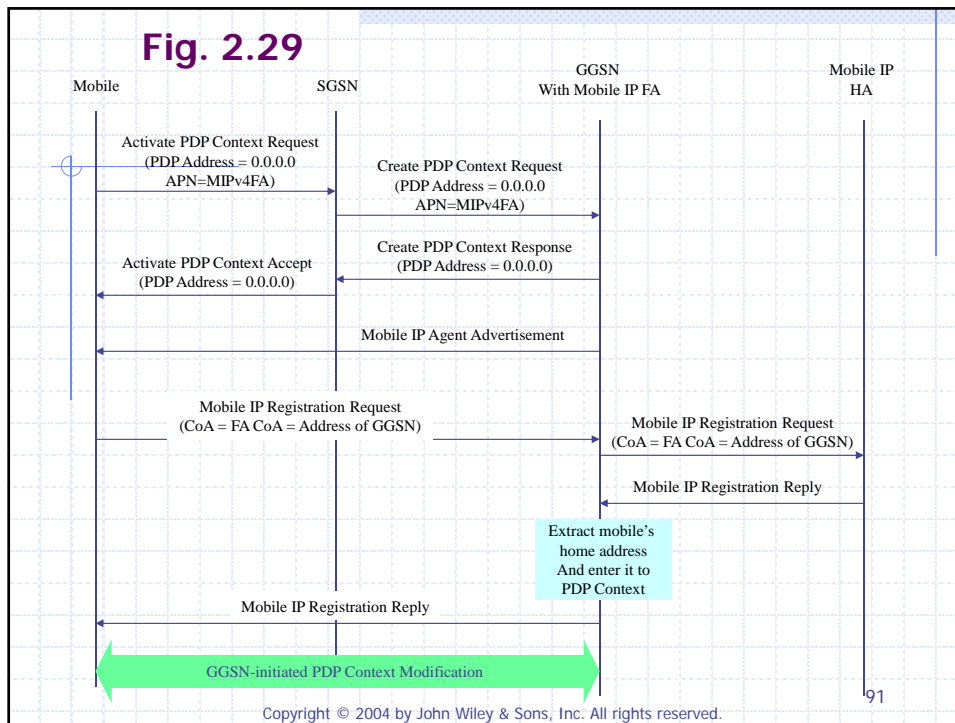

### 2.1.12.3 Acquiring IP Address Dynamically Using DHCP from an External Network

- ◆ Before an IP address is assigned to the mobile by the external IP network, the PS CN domain should be able to relay DHCP messages between the mobile and external DHCP server.
- ◆ When an IP address is assigned to the mobile by the external IP network, the mobile's PDP contexts on the SGSN and the GGSN need to be updated to include the mobile's IP address.

**Fig. 2.30** 3GPP protocol stacks for supporting IP address assignment by external network using DHCP

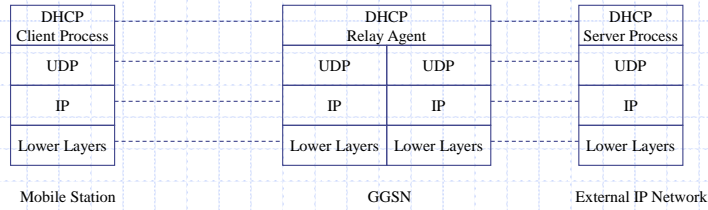

Copyright © 2004 by John Wiley & Sons, Inc. All rights reserved.

93

**Fig. 2.31**

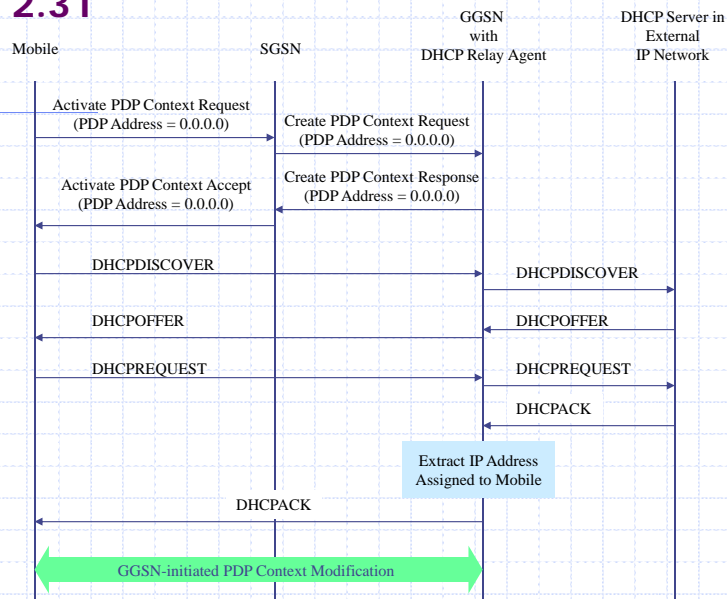

Copyright © 2004 by John Wiley & Sons, Inc. All rights reserved.

94

## 2.1.12.4 Dial-up Access Using PPP

- ◆ Dialup refers to the process of establishing a link-layer connection to an IP network
- ◆ PPP connection is a natural choice for implementing the portion of a dialup connection over the PS domain
- ◆ L2TP may be used to extend the PPP connection from GGSN to external IP network

**Fig. 2.32** Protocol stacks for dialup through 3GPP packet domain to an IP network

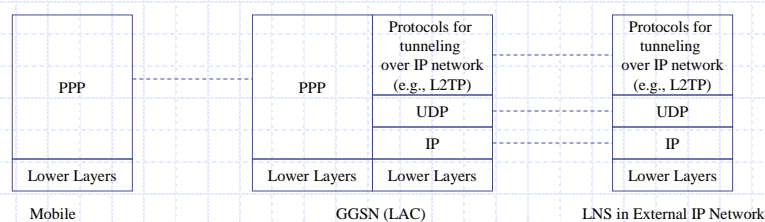



**Fig. 2.33** Signaling flows for dialup through 3GPP packet domain to an IP network

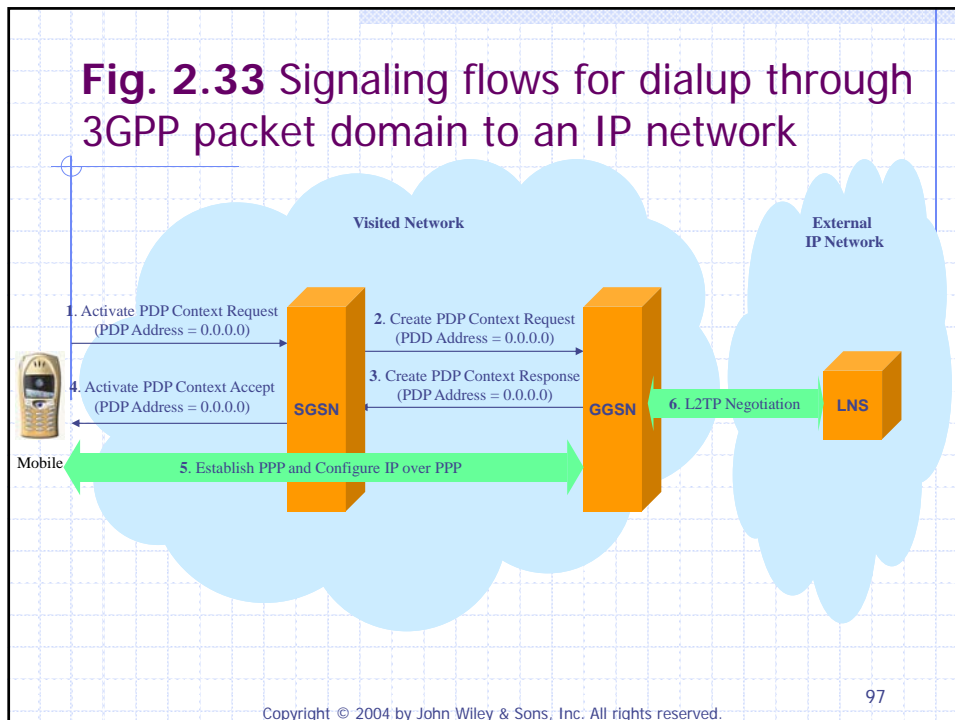

## 2.2 3GPP2 PACKET DATA NETWORKS

- ◆ 2.2.1 3GPP2 Network Architecture
- ◆ 2.2.2 3GPP2 Packet Data Network Architecture
- ◆ 2.2.3 Protocol Reference Model
- ◆ 2.2.4 Access to 3GPP2 Packet Data Network
- ◆ 2.2.5 User Packet Routing and Transport
- ◆ 2.2.6 Protocol Stacks for Packet Data Services

## 2.2.1 3GPP2 Network Architecture

- ◆ Core network
  - circuit-switched domain
  - packet-switched domain
- ◆ Radio Networks (RNs): based on circuit-switched technologies and is used for both circuit-switched and packet-switched services

## Radio Networks (RNs)

- ◆ cdma2000 base station
  - System ID (SID): identify a system
  - Network ID (NID): identify a network
  - pair (SID, NID)
  - (SID, NID): uniquely identify a network within a system
- ◆ Base Station (BS)
  - Base Station Controller (BSC)
  - Base Transceiver System (BTS)

**Fig. 2.34 3GPP2 conceptual network architecture**

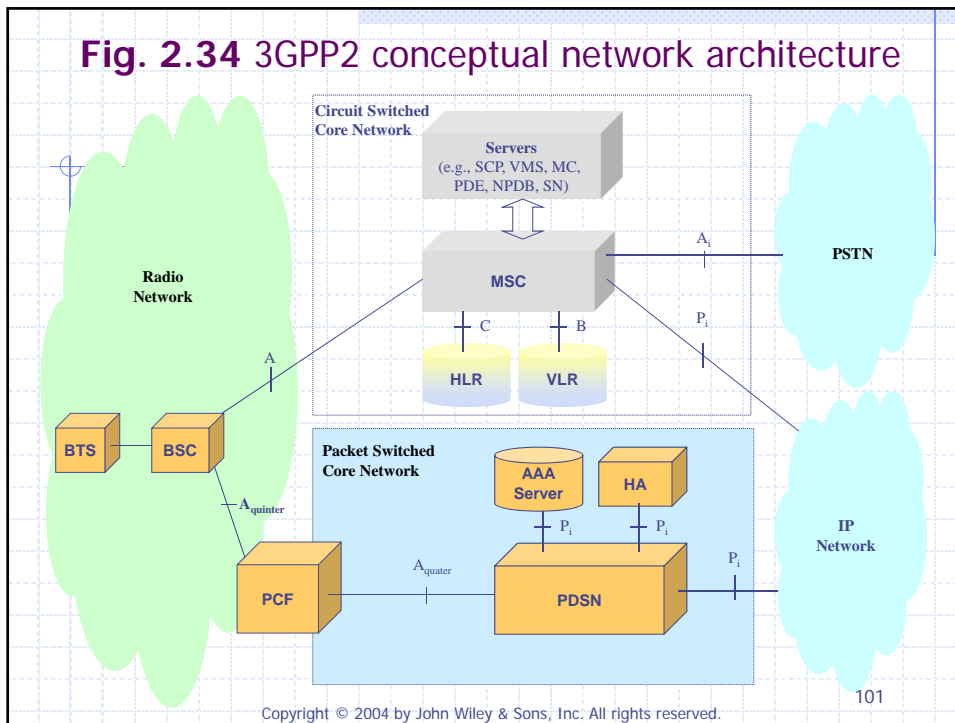

## 2.2.1.1 Circuit-Switched Core Network

- ◆ Switching and call control components
  - Mobile Switching Center (MSC)
- ◆ Information Servers
  - Home Location Registrar (HLR)
  - Visitor Location Registrar (VLR)
  - Equipment Identity Registrar (EIR)
- ◆ Service control servers
  - Service Control Point (SCP)
  - Voice Message System (VMS)
  - Message Center (MC)
  - Position Determining Entity (PDE)
  - Number Portability Database (NPDB)
  - Service Node (SN)

## 2.2.2 3GPP2 Packet Data Network Architecture

- ◆ 2.2.2.1 Functional Architecture
- ◆ 2.2.2.2 Reference Network Architecture

### 2.2.2.1 Functional Architecture

- ◆ Packet Data Serving Node (PDSN)
- ◆ Packet Control Function (PCF)
- ◆ Radio Resource Control (RRC)
- ◆ Mobile Station (MS)
- ◆ Home Agent (HA)
- ◆ Authentication, Authorization, Accounting (AAA)

**Fig. 2.35** 3GPP2 packet data network functional architecture

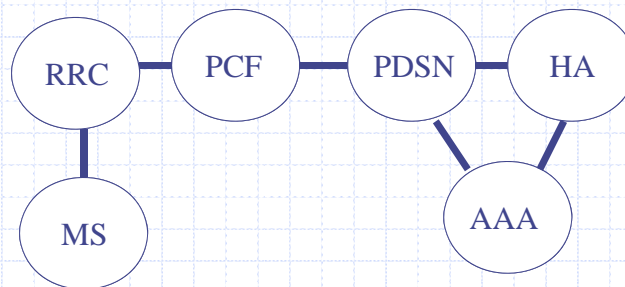

Copyright © 2004 by John Wiley & Sons, Inc. All rights reserved.

105

## Packet Data Serving Node (PDSN)

- ◆ Route IP packets between the 3GPP2 network and any external IP networks
- ◆ Route IP packets between mobile terminals inside the same operator's 3GPP2 network
- ◆ Act as an IP address server to assign IP address to mobiles
- ◆ Act as a PPP server for mobiles (i.e., establish, maintain and terminate PPP session to a mobile terminal)
- ◆ Provide mobility management functions (FA)
- ◆ Communicate with an AAA server to authenticate and/or authorize MS

Copyright © 2004 by John Wiley & Sons, Inc. All rights reserved.

106

## Packet Control Function (PCF)

- ◆ Establish, maintain, and terminate layer-2 connections to the PDSN
- ◆ Maintain reachability information for mobile terminals
- ◆ Relay IP packets between RN and PDSN
- ◆ Tracks status of radio resources
- ◆ Communicate with RRC function on the BSC to manage radio resources

## Radio Resource Control (RRC)

- ◆ Establish, maintain, and terminate radio connections to mobiles and management radio resources allocated to these connections
- ◆ Broadcast system information to mobiles
- ◆ Maintain status of mobile terminals (e.g., active, dormant)

## Mobile Station (MS)

- ◆ User Identity Module (UIM): removable or integrated into ME
- ◆ Mobile Equipment (ME)
  - Terminal Equipment (TE)
  - Mobile Terminal (MT)
  - Terminal Adapter (TA)

Copyright © 2004 by John Wiley & Sons, Inc. All rights reserved.

109

**Fig. 2.36** Functional architecture of a mobile station (MS)

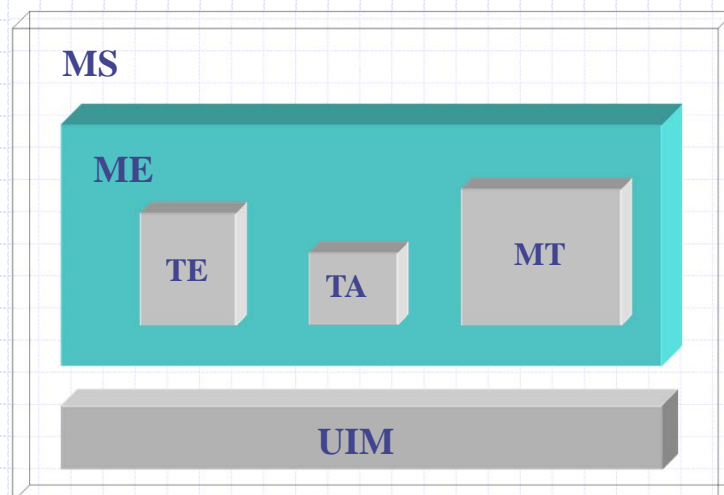

Copyright © 2004 by John Wiley & Sons, Inc. All rights reserved.

110

## 2.2.2.2 Reference Network Architecture

- ◆ Simple IP Access
  - mobile is assigned an IP address dynamically by PDSN
  - obtain a new IP address when MS moves to a new PDSN
- ◆ Mobile IP Access
  - Mobile IP (v4 or v6)

**Fig. 2.37** 3GPP2 packet data network reference physical architecture

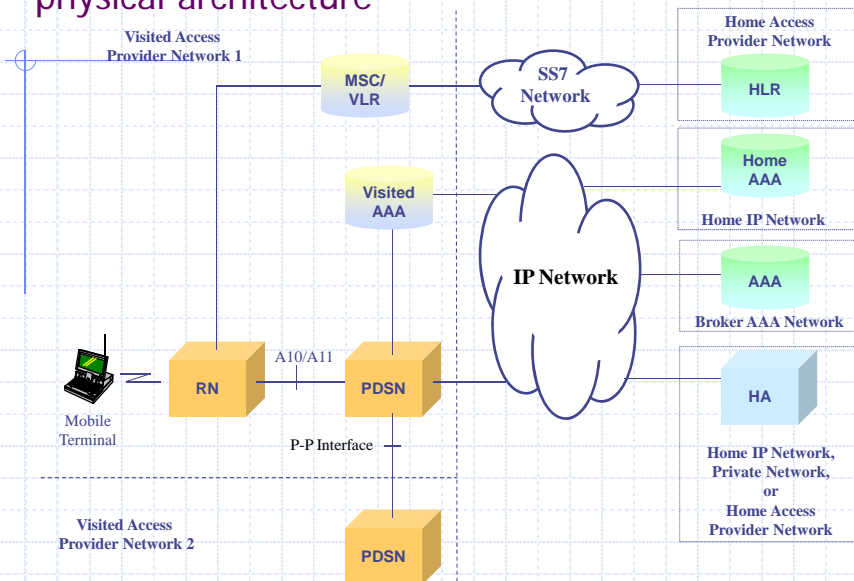



## IPv6

- ◆ PDSN acts as an IPv6 access router
- ◆ PPP is established between MS and PDSN
- ◆ IPv6 over PPP
- ◆ PDSN sends Router Advertisement
- ◆ MS can use IPv6 stateless autoconfiguration to construct and configure a local IPv6 address

## Relation with CS Network

- ◆ Many critical capabilities in PS network rely on CS network
  - handoff, paging, connection setup
- ◆ PS network does not directly interface with the CS network
- ◆ CS procedures are initiated by the BSC inside RN upon receiving data or requests from PCF

## 2.2.3 Protocol Reference Model

- ◆ A Reference Point
- ◆ A<sub>ter</sub> Reference Point
- ◆ A<sub>quinter</sub> Reference Point
- ◆ A<sub>quarter</sub> Reference Point
- ◆ P-P Interface (optional)
  - PDSN-to-PDSN Interface is used support fast handoff between PDSNs

### Fig. 2.38 3GPP2 protocol reference model

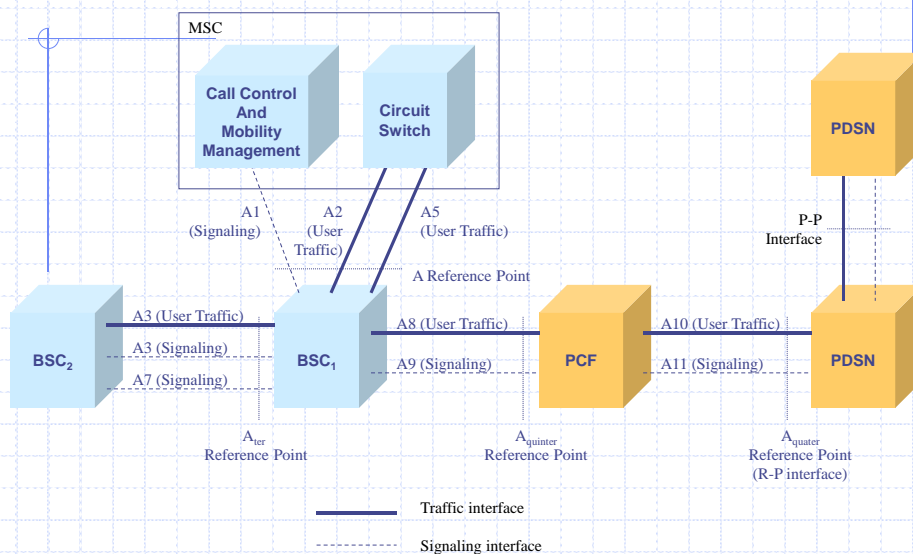

## A Reference Point

- ◆ Interface A1: carry signaling traffic between the Call Control and Mobility Management functions of the MSC and the Call Control function of the BSC
- ◆ Interface A2 and A5: carry different types of user traffic between the switch component of MSC and Selection and Distribution Unit (SDU) on BSC

## A<sub>ter</sub> Reference Point

- ◆ Interface A3: carry signaling and user traffic between SDU on a source BSC and a target BTS for supporting soft handoff
  - A3 signaling controls the allocation and use of A3 user traffic channels
- ◆ Interface A7: carry other signaling information not carried by the A3 interface between a source and a target BS

## A<sub>quinter</sub> Reference Point

- ◆ A8 interface: transport user data traffic
- ◆ A9 interface: signaling between a BSC and a PCF
- ◆ The A8 and A9 interfaces are also used to support mobility between BSCs under the same PCF

## A<sub>quarter</sub> Reference Point (R-P Interface)

- ◆ A10 interface: provide a path for user traffic
- ◆ A11 interface: signaling between the PCF and the PDSN
- ◆ The A10 and A11 interfaces are also used to support mobility between PCFs under the same PDSN

## 2.2.4 Access to 3GPP2 Packet Data Network

- ◆ Step 1: Gain access to PDSN
  - Step 1-A: Gain access to the Radio Network.
  - Step 1-B: Setting up resources between the BSC and the PDSN.
    - ◆ May not need to set up A8 connection
  - Step 1-C: Establish PPP connection between mobile and PDSN.
- ◆ Step 2: MIPv4 registration

Copyright © 2004 by John Wiley & Sons, Inc. All rights reserved.

121

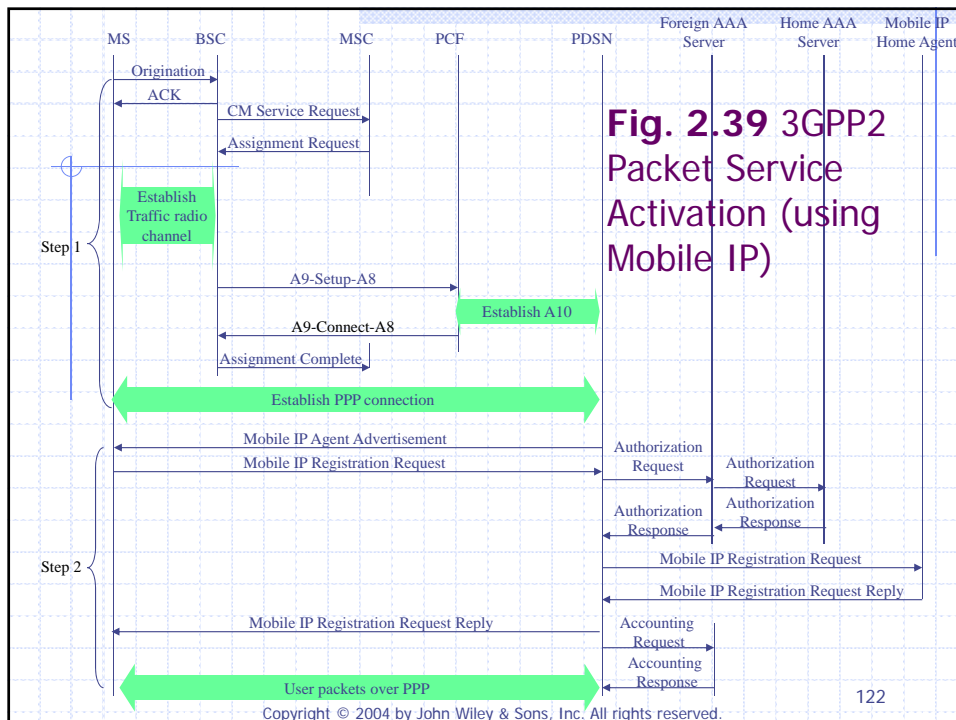

**Fig. 2.39** 3GPP2 Packet Service Activation (using Mobile IP)

Copyright © 2004 by John Wiley & Sons, Inc. All rights reserved.

122

## 2.2.5 User Packet Routing and Transport

- ◆ Mobile maintains a PPP connection to its serving PDSN
- ◆ All user packets to and from the mobile will be sent to the serving PDSN first
- ◆ A8 and A10 connections are implemented as IP tunnels using Generic Routing Encapsulation (GRE)

Copyright © 2004 by John Wiley & Sons, Inc. All rights reserved.

123

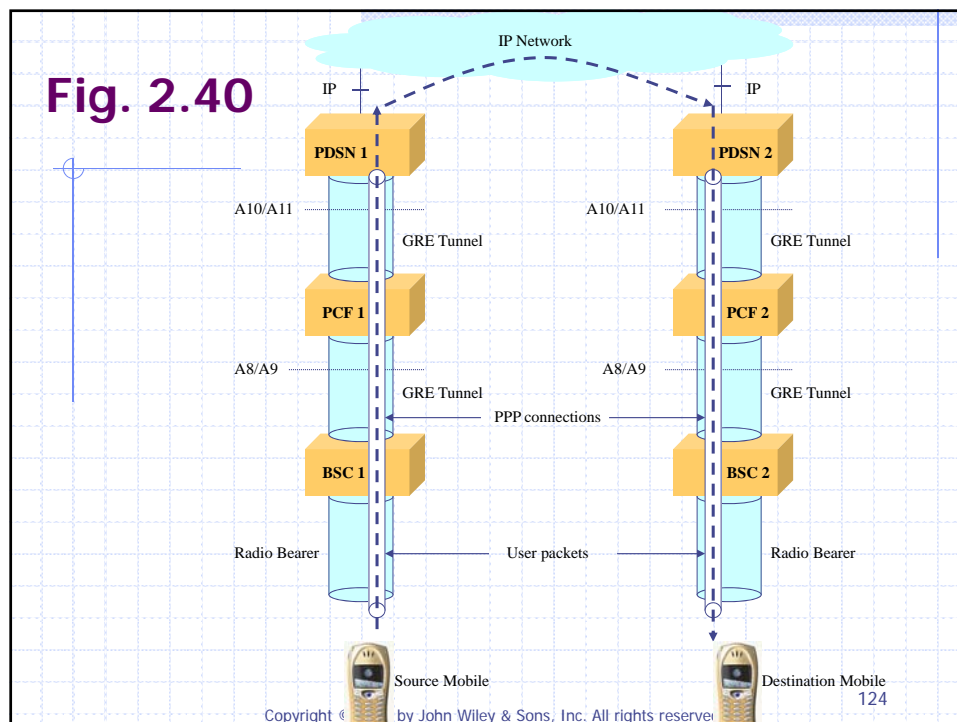

## 2.2.6 Protocol Stacks for Packet Data Services

- ◆ 2.2.6.1 Protocol Stacks over A9 and A11 Interfaces
- ◆ 2.2.6.2 Protocol Stacks over A8 and A10 Interfaces
- ◆ 2.2.6.3 Protocol Stacks over P-P Interface
- ◆ 2.2.6.4 Protocol Stacks Between Mobile and PDSN

### 2.2.6.1 Protocol Stacks over A9 and A11 Interfaces

- ◆ Main messages of A9
  - *A9-Setup-A8 and A9-Connect-A8*
  - *A9-Release-A8 and A9-Release-A8 Complete*
  - *A9-Disconnect-A8*
  - *A9-Update-A8 and A9-Update-A8 Ack*
  - *A9-Air Link (AL) Connected and A9-Air Link (AL) Connected Ack*
  - *A9-Air Link (AL) Disconnected and A9-Air Link (AL) Disconnected Ack*

## 2.2.6.1 Protocol Stacks over A9 and A11 Interfaces (Cont.)

- ◆ A11 signaling protocol is modeled after the Mobile IPv4 protocol
  - PDSN acts as if it was a MIPv4 HA
  - PCF acts as if it was a MIPv4 FA
- ◆ Main messages of A11
  - *A11 Registration Request*
  - *A11 Registration Reply*
  - *A11 Registration Update*
  - *A11 Registration Acknowledge*
- ◆ Soft state: PCF periodically sends *A11 Registration Request* to refresh A10 connection

**Fig. 2.41** 3GPP2 protocol stacks for the A9 and A11 interfaces

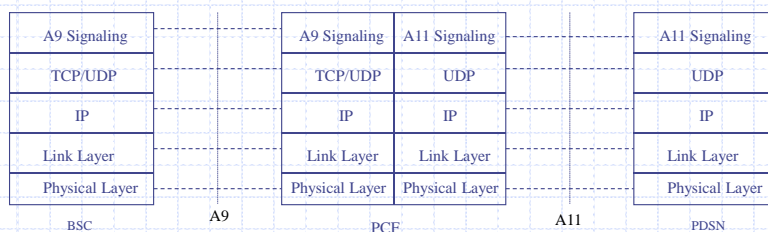



## 2.2.6.2 Protocol Stacks over A8 and A10 Interfaces

- ◆ GRE encapsulates a user packet by adding a GRE header to the user packet
- ◆ Sequence Number: ensure packet delivery order
- ◆ Key: identify the IP packets to and from each mobile terminal
  - PCF Session Identifier (PCF SID)
  - PDSN Session Identifier (PDSN SID)

Copyright © 2004 by John Wiley & Sons, Inc. All rights reserved.

129

**Fig. 2.42** 3GPP2 protocol stacks for the A8 and A10 interfaces

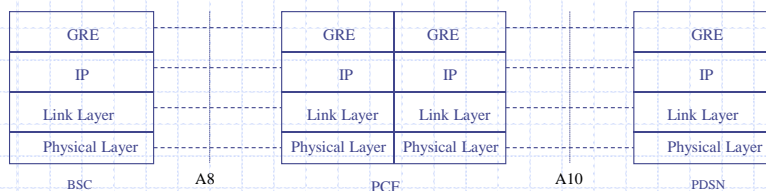

Copyright © 2004 by John Wiley & Sons, Inc. All rights reserved.

130

**Fig. 2.43** Generic Routing Encapsulation (GRE) protocol header

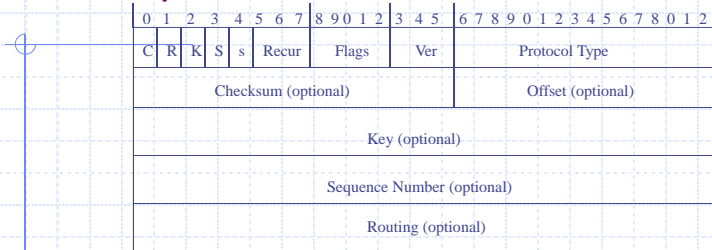

(a) GRE header format.

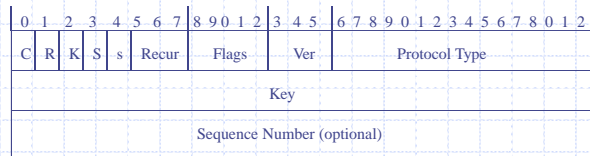

(b) Format of GRE header used for tunneling between PCF and PDSN or between BSC and PCF.  
Copyright © 2004 by John Wiley & Sons, Inc. All rights reserved.

### 2.2.6.3 Protocol Stacks over P-P Interface

- ◆ The P-P interface is an optional interface used to support fast inter-PDSN handoff (see 4.4.4)
- ◆ Two individual interfaces
  - P-P Bearer Interface: P-P traffic connection to tunnel user packets between the PDSNs by GRE tunnel
  - P-P Signaling Interface: signaling messages and procedures for managing the P-P traffic connections

## P-P Signaling

- ◆ Modeled after the Mobile IPv4 protocol
  - Serving PDSN acts as if it was a MIPv4 HA
  - Target PDSN acts as if it was a proxy/MIPv4 FA
- ◆ Main messages of A11
  - *A11 Registration Request*
  - *A11 Registration Reply*
  - *A11 Registration Update*
  - *A11 Registration Acknowledge*

Copyright © 2004 by John Wiley & Sons, Inc. All rights reserved.

133

## Fig. 2.44 Protocol stacks for the P-P interface



(a) Control-plane protocol stack

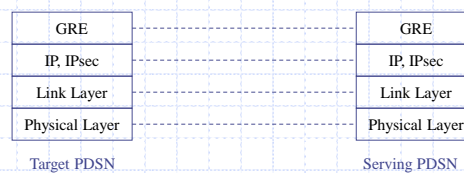

(b) User-plane protocol stack

Copyright © 2004 by John Wiley & Sons, Inc. All rights reserved.

134

## 2.2.6.4 Protocol Stacks Between Mobile and PDSN

- ◆ Mobile is not in the process of fast inter-PDSN handoff (without P-P interface)
  - Link Access Control (LAC): establish, use, modify, remove of radio links
- ◆ With P-P interface
- ◆ Signaling between a mobile and its serving PDSN
  - Set up PPP
  - MIPv4 registration

**Fig. 2.45** 3GPP2 protocol stacks for user data between mobile terminal and PDSN (without P-P interface)

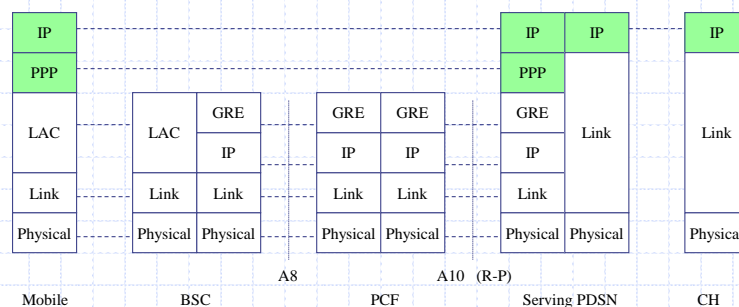

**Fig. 2.46** Protocol stacks for end-to-end user traffic transport when P-P interface is used

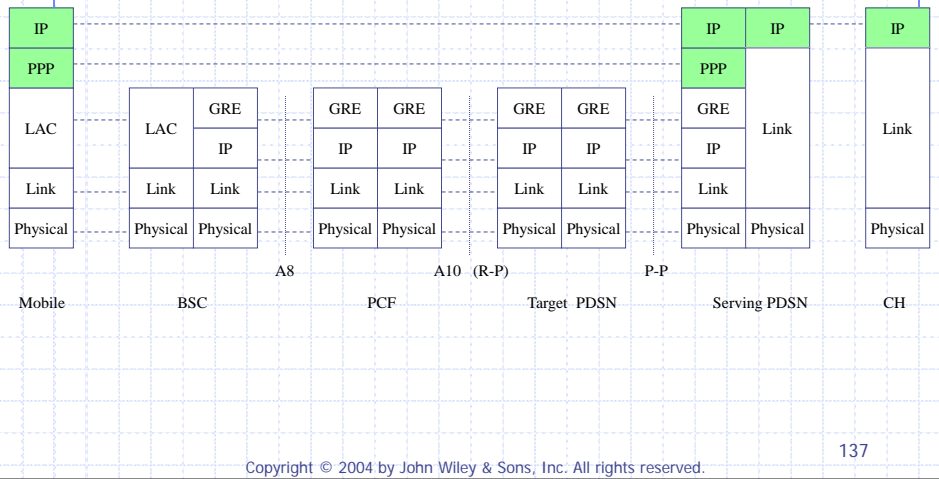

**Fig. 2.47** 3GPP2 protocol stacks for signaling between mobile terminal and PDSN

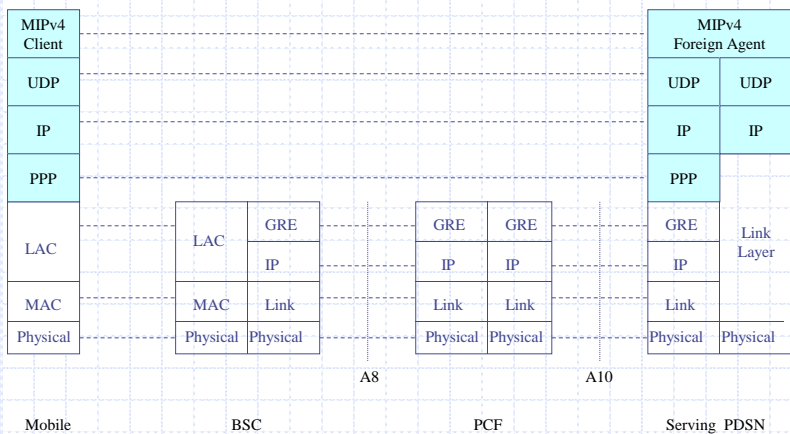

## 2.3 MWIF ALL-IP MOBILE NETWORKS

- ◆ MWIF seeks to develop an end-to-end all-IP wireless network that will use IETF protocols to support all networking functions at the network-layer and higher layers, including naming and addressing, signaling, service control, routing, transport, mobility management, quality of service mechanisms, security, accounting, and network management.
- ◆ Unlike the 3GPP and 3GPP2 networks, the MWIF architecture will no longer rely on protocols or network entities in circuit-switched core networks.

Copyright © 2004 by John Wiley & Sons, Inc. All rights reserved.

139

### 2.3.1 Network Architectures

- ◆ Core Network
  - All-IP using standard IETF protocols
  - Independent of access-specific technologies used in different Access Networks
- ◆ Access Networks

Copyright © 2004 by John Wiley & Sons, Inc. All rights reserved.

140

## Layered Functional Architecture

- ◆ Transport Layer (in both Access Network and Core Network)
  - ◆ Control Layer
  - ◆ Service Layer
  - ◆ Application Layer
- ◆ The security and the OAM&P (Operation, Administration, Maintenance and Provisioning) functions may span across multiple functional layers.

141

Copyright © 2004 by John Wiley & Sons, Inc. All rights reserved.

**Fig. 2.48**

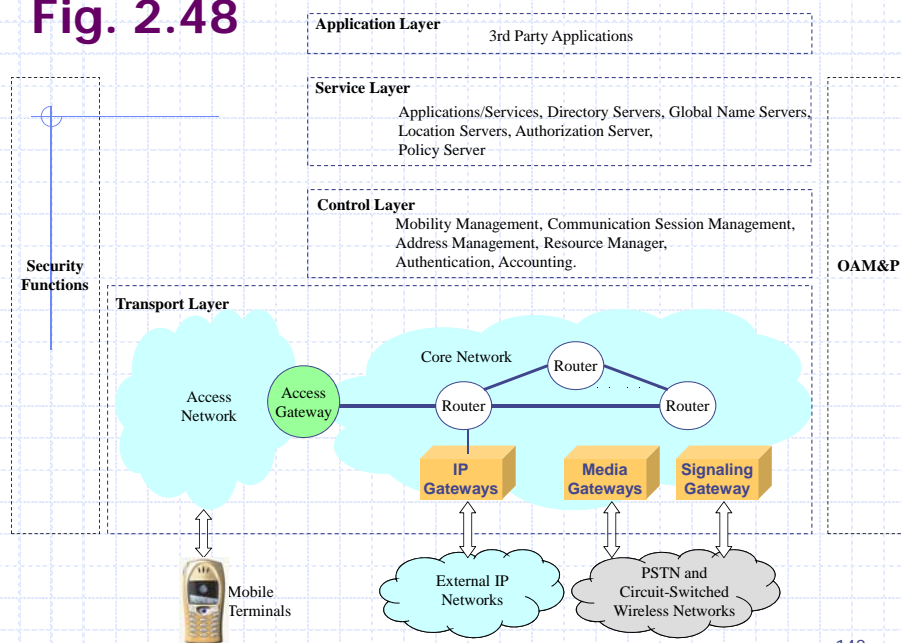

142

Copyright © 2004 by John Wiley & Sons, Inc. All rights reserved.

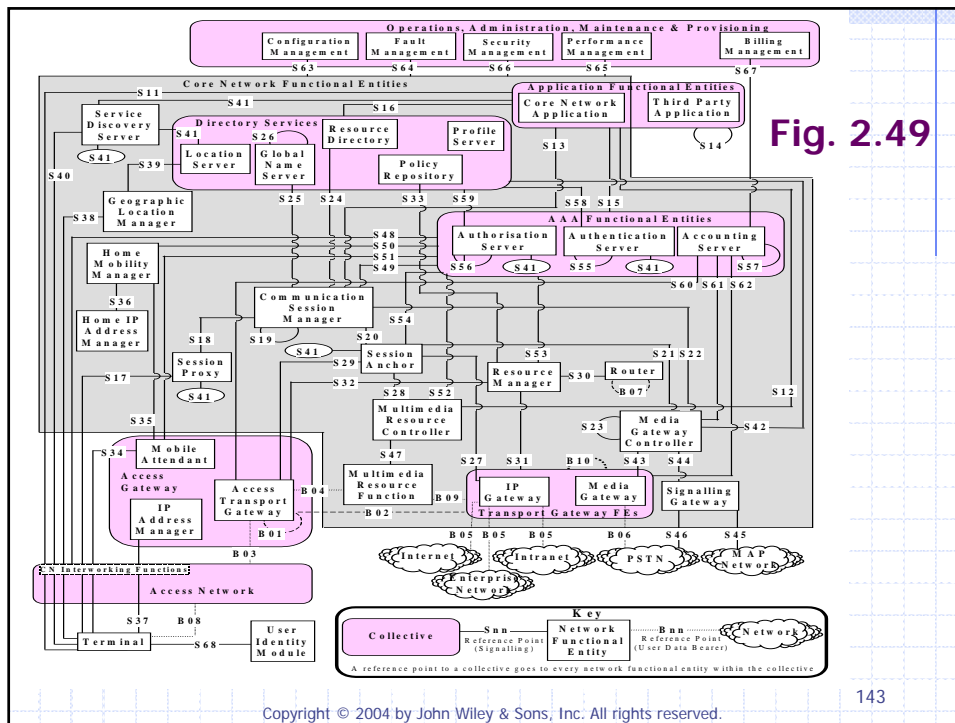

143

## 2.3.2 Access to MWIF Networks

- ◆ Access Network Registration
  - Specific to each access network
- ◆ Basic Registration for Core Network
  - Enable a mobile to gain access to the core network and to send and receive IP packets over the core network
- ◆ SIP Registration
  - Enable a user to use SIP to initiate and receive multimedia communications
  - An integral part of session and service management

Copyright © 2004 by John Wiley & Sons, Inc. All rights reserved.

144



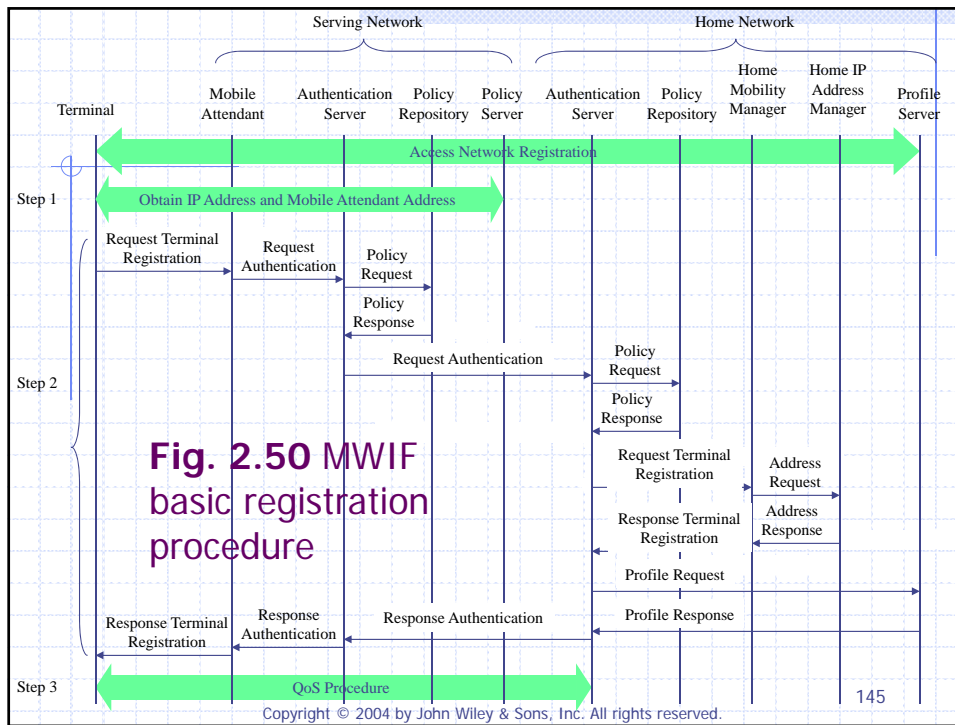

## 2.3.3 Session Management

- ◆ 2.3.3.1 Functional Entities, Protocol Reference Points and Stacks
- ◆ 2.3.3.2 Mobile-Initiated Call Setup

